



Motion Detectors

Requirements and test methods

Publishing house: VdS Schadenverhütung GmbH

Amsterdamer Str. 172-174

50735 Köln, Germany

Phone: +49 221 77 66 0; Fax: +49 221 77 66 341

Copyright by VdS Schadenverhütung GmbH. All rights reserved.

VdS Guidelines for Intruder Alarm Systems

Motion Detectors

Requirements and test methods

Contents

1	General	5
1.1	Scope	5
1.2	Validity.....	5
2	Normative references	6
3	Terms and definitions	6
3.1	Standard walk test target	6
3.2	Basic detection target	7
3.3	Abbreviations	7
4	Classification	7
5	Functional reliability	7
5.1	Processing of events as well as signals or messages	9
5.2	Response behaviour	9
5.3	Immunity against unwanted triggering and false masking.....	10
5.4	Overriding by bypassing monitoring methods	11
5.5	Suppression of faults	11
5.6	Triggering detection	11
5.7	Functional test.....	12
5.8	Tamper	12
6	Functional reliability	14
6.1	Function monitoring	14
6.2	Operational requirements	15
6.3	Constructive requirements	16
7	Functional security and operation	16
7.1	Constructional requirements.....	17
7.2	Disposition of function.....	17
7.3	Operation	18
8	Interface to the intruder/hold-up alarm system	19
8.1	Interface for conventional line technology	19
8.2	Interface for other technologies	21
9	Protection against environmental influences	21
9.1	Limits of application	21
9.2	Climates (sun radiation).....	23
10	General conditions and test conditions	23
10.1	General	23
10.2	Conditions	23
10.3	Determination of test extent.....	24
10.4	Test methods	24
10.5	Basic detection test.....	24
11	Receiving controls	25
11.1	Check on completeness	25
11.2	Test on basic functions	25
11.3	Test on adjustment values	25
11.4	Initial running.....	25
11.5	General tests.....	25

12	Test of function	26
12.1	Response behaviour	26
12.2	Conditions for walk tests according to EN 50131-BWM	26
12.3	Walking without interruption	27
12.4	Walking with intermittent movement	32
12.5	Immunity against unwanted alarms	32
12.6	Overriding by bypassing the monitoring method	39
12.7	Triggering identification	39
12.8	Function test	40
12.9	Tamper	40
13	Test on functional reliability	44
13.1	Function monitoring	44
13.2	Functional reliability during operation	45
13.3	Constructional requirements	49
14	Test of operational reliability and operation	49
14.1	Constructional requirements	49
14.2	Provision of functions	51
14.3	Operation	51
15	Test of the interfaces to the IAS/HAS	52
15.1	Interface for conventional line technology	52
15.2	Test of the interface for other techniques	54
16	Protection against environmental influences	55
16.1	Limits of application	55
16.2	Climates (sun radiation)	55
Annex A (normative) – dimensions and requirements of standardised test magnets		56
Annex B (normative) – Test matrix		58
Annex C – Procedure for the calculation of the average temperature difference		60
Annex D – Equipment for walk test velocity control		61

1 General

1.1 Scope

These guidelines contain minimum requirements and test methods for motion detectors with volumetric monitoring characteristics in classes A, B and C. These guidelines shall be applied in conjunction with the "Guidelines for Intruder Alarm Systems, General Requirements and Test Methods"; VdS 2227 and the "Guidelines for Intruder Alarm Systems, Protection against Environmental Influences, Requirements and Test Methods", VdS 2110. The "Guidelines for Alarm Systems, Software Controlled System Components, Supplementary Requirements and Test Methods", VdS 2203, also apply for system components controlled by software.

These guidelines also apply to intruder detectors which use similar technologies like motion detectors but have different monitoring characteristics (e.g. the types known as "curtain detectors", "single-beam detectors", "passive" infrared beam detectors, etc.). Here the section 5 ff. apply in analogy.

These guidelines contain the requirements and test methods of the European standards

- DIN EN 50131-2-2, Alarm Systems – Intrusion and hold-up systems, Part 2-2: passive infrared detectors, version 2008-05
- DIN EN 50131-2-3, Alarm Systems – Intrusion and hold-up systems, Part 2-3: Requirements for microwave detectors, version 2009-05
- DIN EN 50131-2-4, Alarm Systems – Intrusion and hold-up systems, Part 2-4: Requirements for combined passive infrared detectors and microwave detectors, version 2008-10
- DIN EN 50131-2-5, Alarm Systems – Intrusion and hold-up alarm systems, Part 2-5: Requirements for combined passive infrared and ultrasonic detectors, version 2009-05

This means that

- Motion detectors that fulfil the requirements of class A at least fulfil the requirements for grade 1 of respective EN
- Motion detectors that fulfil the requirements of class B at least fulfil the requirements for grade 2 of respective EN
- Motion detectors that fulfil the requirements of class C at least fulfil the requirements for grade 3 of respective EN
- Motion detectors that fulfil the requirements of class A at least fulfil the requirements for grade 1 of respective EN

If motion detectors shall comply with the requirements of the European standard (e. g. 50131-2-2) for a higher grade, additional requirements are to be fulfilled (e. g. tamper detection), which are described for the higher grade. Requirements of VdS which supersede the requirements of the EN or even do not exist in the standard, are marked or explicitly highlighted as such.

1.2 Validity

These guidelines are valid from 01.12.2010; they replace the edition VdS 2312 : 1999-12 (03) as well as VdS 2326 : 2001-12 (01).

Note: This is a translation of the German guidelines; if there are any discrepancies, the German version shall be binding.

2 Normative references

These guidelines contain dated and undated references to other publications. The normative references are cited at the appropriate places in the clauses, the publications are listed hereafter. For dated references, subsequent amendments to or revisions of any of these publications apply to these rules only when announced by a change of these rules. For undated references the latest edition of the publication referred will be applied.

- DIN 41 636 Sensitive switches for communication technology
- DIN 45 631 Procedure for calculating loudness level and loudness
- DIN EN 50131-1, Alarm systems – Intrusion and hold-up systems, part 1: system requirements
- DIN EN 50131-2-2, Alarm systems – Intrusion and hold-up systems, part 2-2: requirements for passive infrared detectors
- DIN EN 50131-2-3, Alarm systems – Intrusion and hold-up systems, part 2-3: requirements for microwave detectors
- DIN EN 50131-2-4, Alarm systems – Intrusion and hold-up systems, part 2-4: requirements for combined passive infrared and microwave detectors
- DIN EN 50131-2-5, Alarm systems – Intrusion and hold-up systems, part 2-5: requirements for combined passive infrared and ultrasonic detectors
- DIN EN 50131-6, Alarm systems – Intrusion and hold-up systems, part 6: power supply
- DIN EN 60529, Degrees of protection provided by enclosures (IP-Code)
- DIN EN 60950, Information technology equipment – corresponds with VDE 0805
- DIN VDE 0100, Low-Voltage electrical installations, with rated voltages up to 1000 V
- DIN 45631, Procedure for calculating loudness level and loudness
- DIN VDE 0833-1, Alarm systems for fire, intrusion and hold-up, general requirements
- DIN VDE 0833-3, Alarm systems for fire, intrusion and hold-up, Requirements for Intrusion and hold-up systems
- VdS 2110 Guidelines for intruder alarm systems, protection against environmental influences, requirements and test methods
- VdS 2203 Guidelines for alarm systems, software controlled system components, supplementary requirements and test methods
- VdS 2227 Guidelines for intruder alarm systems, general requirements and test methods

3 Terms and definitions

For general terms and definitions refer to the “Guidelines for Intruder Alarm Systems, General Requirements and Test Methods”, VdS 2227.

3.1 Standard walk test target

Person with normal weight and normal height which shall correspond with an intruder with closely fitting.

3.2 Basic detection target

Source for the physical detection parameter (e. g. heat source for passive infrared detectors) for verification of the function.

3.3 Abbreviations

EN 50131-2-x Summary of definitions of the relevant European Standards for motion detectors.

- DIN EN 50131-2-2, Alarm systems – Intrusion and hold-up systems, Part 2-2: Requirements for passive infrared detectors, version 2008-05
- DIN EN 50131-2-3, Alarm systems – Intrusion and hold-up systems, Part 2-3: Requirements for microwave detectors, version 2009-05
- DIN EN 50131-2-4, Alarm systems – Intrusion and hold-up systems, Part 2-4: Requirements for combined passive infrared detectors and microwave detectors, version 2008-10
- DIN EN 50131-2-5, Alarm systems – Intrusion and hold-up systems, Part 2-5: Requirements for combined passive infrared and ultrasonic detectors, version 2009-05

SWT – standard walk test target

BDT – basic detection target

4 Classification

The **performance criteria** for different classes are defined in the “Guidelines for Intruder Alarm Systems, General Requirements and Test Methods”, VdS 2227. An alignment of the requirements and test methods according to security grade from the standard series EN 50131 (compare DIN EN 50131-1, Alarm systems – Intrusion and hold-up systems, clause 6) is also made.

The **environmental classes** are set in accordance with the “Guidelines for Intruder Alarm Systems, Protection against Environmental Influences, Requirements and Test Methods”, VdS 2110.

5 Functional reliability

Motion detectors shall be designed such that they detect and signal an intrusion/intrusion attempt with a high probability at the earliest time possible.

Depending on the class the requirements on the function may differ.

Clause of these guidelines	Function	VdS class A	VdS Class B	VdS class C
5.1	Processing of signals and messages			
5.2	Detection/response behaviour			
	At the monitoring detection boundary	4	4	4
	With high velocity	4	4	4
	With low velocity	1	3	4

Clause of these guidelines	Function	VdS class A	VdS Class B	VdS class C
	Detection in the close-up range	③	③	④
	Walking with interruption		④	④
5.3	Immunity against unwanted triggering or deceptive masking			
5.3.2	Exceeding the specified detection range	VdS	VdS	VdS
5.3.3	Movements of small objects in the area of the detection range	VdS	VdS	VdS
5.3.4	Movement of small objects on the floor of the detection range	VdS	VdS	VdS
5.3.5	Movement of small objects in the inside of the detector	VdS	VdS	VdS
5.3.6	Oscillating motion in the detection range	VdS	VdS	VdS
5.3.7	Light radiation	⌚	⌚	⌚
5.3.8	Light sources in the detection range	●	●	●
5.3.9	Air streams and turbulences	●	●	●
5.3.10	Sound sources	●	●	●
5.3.11	Immunity against deceptive maskings	●	●	●
5.4	Override by bypassing the monitoring method	VdS	VdS	VdS
5.5	Suppression of faults	VdS	VdS	VdS
5.6	Triggering detection	VdS	VdS	VdS
5.7	Functional test	⌚	⌚	⌚
5.8	Tamper security			
5.8.1	Tamper protection	●	●	●
5.8.2	Tamper monitoring	Op③	③	③
5.8.2.1	Detection of opening	Op②	②	③
5.8.2.2	Detection of masking	Op③	Op③	⌚
5.8.2.3	Detection of removal from the mounting surface	Op③ ^a Op② ^b	Op③ ^a ② ^b	③ ^a ③ ^b
5.8.3	Immunity against magnetic influences	Op②	④	④
5.8.4	Significant reduction of range	NA	NA	Op④
<p>①, ②, ③, ④ VdS requirement corresponds with the requirement of the shown grade of EN 50131-BWM (example: ● -> VdS requirement corresponds with EN 50131-BWM for grade 2)</p> <p>● VdS requirement corresponds with the respective requirement of the EN 50131-BWM (without grade-dependant differentiation)</p> <p>Op②, Optional for the fulfilment of the shown grade of EN 50131-BWM</p> <p>Op ③ Example: Op② Requirement is valid optionally for the fulfilment of grade 2 of EN 50131-BWM</p> <p>⌚ VdS requirement exceeds the respective requirement of EN 50131-BWM</p> <p>VdS additional VdS requirement without equivalent in EN 50131-BWM</p> <p>NA not applicable</p> <p>a wired</p> <p>b wire-free</p>				
Table 5.01: Overview on functions				

5.1 Processing of events as well as signals or messages

A motion detector shall process and signal correspondingly the events as listed in the following table:

Event	Processing per class	Messages and signals		
		Intrusion	Tamper	Fault
Intrusion	A,B,C	M	NP	NP
Tamper	BC	NP	M	NP
Masking ^a	C	M	NP ^c	M
Significant reduction of range ^a	Op ^④	M	NP ^c	M
Low supply voltage	C	Op	NP ^c	M
Total loss of power supply ^b	BC	M	NP ^c	Op
Local self test pass	C	NP	NP	NP
Local self test fail	C	NP	NP	M
Remote self test pass	Op ^④	M	NP	NP
Remote self test fail	Op ^④	NP	NP	M
M	Mandatory			
NP	Not permitted			
Op ^④	Optional up to grade 4			
^a	An independent signal or message may be provided instead.			
^b	Alternatively total loss of power supply shall be determined by loss of communication with the detector.			
^c	Triggering of the tamper signal is optionally admitted according to the EN. The restriction that no tamper message/tamper signal is generated is one of the options.			
Table 5.02: Messages and signals				

5.2 Response behaviour

The response behaviour of the detector shall fulfil the following requirements on the detection.

5.2.1 Walking without interruptions

Movements of an adult person which fulfils the specifications of the standard walk test target, shall be signalled when being in the surveillance area of the motion detector as indicated in table 5.03.

Movements of a person in any direction in the surveillance area of a motion detector that are to be signalled			Signal to be triggered after a maximum distance of
Class A	Class B	Class C	
Over the detection boundary upright walking with a velocity of 1 m/s	Over the detection boundary, upright walking with a velocity of 1 m/s	Over the detection boundary upright walking with a velocity of 1 m/s	≤ 2 m
Within the detection boundary, upright walking with a velocity between 0,3 m/s < v < 3 m/s	Within the detection boundary, upright walking with a velocity between 0,2 m/s < v < 3 m/s	Within the detection boundary, upright walking with a velocity between 0,1 m/s < v < 4 m/s	≤ 2 m
Within the detection boundary, crawling ¹⁾ , with a velocity of v = 0,3 m/s at a distance of 2,0 m	Within the detection boundary, crawling ¹⁾ , with a velocity between 0,3 m/s < v < 1 m/s at a distance of 2,0 m ²⁾ ,	Within the detection boundary, crawling ¹⁾ , with a velocity between 0,2 m/s < v < 1 m/s at a distance of 0,5 m	≤ 2 m
¹⁾ crawling (the walk test target shall move with hands and knees on the ground)			
Table 5.03: Response behaviour			

5.2.2. Intermittent walking

Motion detectors shall be designed such that overriding by walking with interruptions is not possible.

A person shall be detected and a signal shall be generated if the person walks in the surveillance area a distance of 1 m with a velocity of appr. 1 m/s upright, then stops for ≤ 5 s, continues to walk etc. The signal shall be triggered at the latest after a distance of 5 m **or** if 50 % of the distance between starting point of the movement and detector have been covered.

5.3 Immunity against unwanted triggering and false masking

5.3.1 General

Motion detectors shall be designed such that other influences than those specified by the triggering criterion do not lead to a signal with a high probability.

5.3.2 Exceeding of the specified surveillance range

The surveillance range of the motion detector as indicated by the manufacturer may be exceeded by 30 % at maximum.

5.3.3 Movements of small objects in the volume of the surveillance range

Movements of small objects or small animals (e. g. by flying bees) in the volume of the surveillance range shall not lead to a signal.

5.3.4 Movements of small objects on the floor of the surveillance range

Movements of small objects or small animals (e. g. mice) on the floor of the surveillance range shall not lead to a signal.

5.3.5 Movements of small objects inside the detector

Movements of small animals (e. g. spiders) inside the detector shall not lead to a signal.

5.3.6 Oscillating motion in the surveillance range

Oscillating motions of objects in the surveillance range (e. g. curtains, signs) shall not lead to a signal.

Note: This requirement is not valid for infrared motion detectors.

5.3.7 Light radiation

The radiation of light (e. g. car lamps, sun light) onto the detector from outside the surveillance range shall not lead to a signal.

5.3.8 Light sources in the surveillance range

Light sources in the vicinity of the surveillance range of the detector (e. g. bulbs, fluorescent tubes) shall not lead to a signal.

5.3.9 Air flows and turbulences

Air flows and turbulences in the surveillance range of the detector (e. g. by heating systems) shall not lead to a signal.

5.3.10 Sound source

In the field, sound sources (e. g. telephone), installed in the vicinity of the detector shall not lead to a signal.

5.3.11 Immunity against false masking signals

No masking signal or masking message shall be generated by the detector for a person walking with normal attitude with a velocity of 0,5 m/s as well as 1 m/s at a distance of 1 m or more.

5.4 Overriding by bypassing monitoring methods

Motion detectors shall be designed such that no overriding of the detectors is possible by measures against unwanted triggering.

5.5 Suppression of faults

The suppression of faults shall not influence the response behaviour of the detectors in a significant manner.

Especially the influence of direct or indirect light radiation shall not lead to changes of the performance features of the detector.

5.6 Triggering detection

Motion detectors that contain electronic parts shall be connected to the IAS such that the operator is able to recognise which detector has triggered. After triggering of these detectors it shall be ensured that in the unset state of the IAS the information on the triggering of the detector is not falsified.

Deletion of these information (e. g. as alarm memory) may be possible for the operator. Information on triggering that are not deleted may be automatically deleted with the setting of the system. Alternatively, these information shall be deliberately deleted by the operator in case the inevitability (German: "Zwangsläufigkeit") of the IAS is concerned.

5.7 Functional test

5.7.1 Functional test by the installer

The function of motion detectors shall be testable by installer and maintenance service. The test functions shall reveal the real functions of the detector.

5.7.2 Functional test by the operator

It shall be possible for the operator of the IAS to test motion detectors in an easy manner. The display of functions shall be unambiguous and perceptible in the vicinity of the respective detector. For detectors of class A it shall be possible to activate and de-activate the display of functions.

Note: For design of displays see clause 7.1.2.

For detectors of class B and C it shall be possible for the operator to switch on/off the function display for functional tests. For class C detectors it shall be possible to remotely control the function displays.

5.8 Tamper

5.8.1 Tamper protection

Housings of motion detectors shall have sufficient mechanical stability. Covers shall be affixed in a mechanical stable manner to the housings. Furthermore the inside of the detectors shall not be visible during intended operation of the detector.

For motion detectors of class B and C the display and control elements shall be designed such that they do not weaken the stability of the housing and do not allow access into the device. Fixing screws of assemblies shall not be visible from the outside once installed as intended. The opening of these detectors shall be possible only with tools. Furthermore, it shall be prevented that persons that are not authorised may change the surveillance range of detectors by turning or breaking off the detector with simple force.

5.8.2 Tamper monitoring

5.8.2.1 Detection of the opening of a motion detector

The opening of detectors of class B and C shall be detected and indicated if security relevant functions become accessible by this opening. The inside of the motion detectors and the opening surveillance shall be protected against access until surveillance has triggered. For cover contacts only snap switches according to DIN 41636 or equivalent equipment shall be used. The contact areas of the switches shall be golden or of equivalent material. Alternatively, protective gas contacts may be used if it is not possible to influence them from the outside.

The minimum response time (dwell time) of the opening surveillance shall be indicated by the manufacturer if the detector disposes of an interface according to clause 8.

5.8.2.2 Detection of masking

A significant reduction of the intended function of class C detectors (e.g. by masking) shall be detected in the unset state of the IAS and shall be signalled. The response time for the masking detection shall be 120 s at maximum. The masking shall be signalled according to the requirements specified in table 5.02. Masking signals and messages shall persist as long as the masked state lasts. It shall not be possible to restore a masking signal or message as long as the masked state lasts. Alternatively, the masking signal or message shall be triggered anew within 120 s if the masking still lasts after the resetting process. The signal shall be triggered when setting the IAS at the latest and shall interfere in the Zwangsläufigkeit of the IAS. It shall not be triggered as tamper signal.

5.8.2.3 Detection of the removal from the mounting surface

The removal from the mounting surface shall be detected and signalled as tamper signal or message for wire-free motion detectors of class B and wired or wire-free motion detectors of class C.

5.8.3 Immunity against magnetic influences

It shall not be possible, to suppress signals or messages with a magnet as specified in annex A. The design of the magnet types shall correspond with those specified in annex A.

5.8.4 Significant reduction of range (optional)

Motion detectors of grade 4 according to EN 50131-BWM shall detect a significant reduction of range or a reduction of the detection range, e. g. the deliberate or undeliberate inserting of objects or shielding in the detection range.

A reduction of range along the main axis of the detection of more than 50 % shall lead to a signal or a message within 180 s according to the requirements of table 5.01 and 5.02.

If additional equipment is necessary for the detection of a significant reduction of range it shall be referred to the manufacturers' documentation on these equipment and its operation.

Note: This is a requirement on the functionality which is specified in EN 50131-BWM for motion detectors of grade 4. The requirement may additionally be tested.

6 Functional reliability

The intended function of the motion detector according to clause 5 shall not be negatively influenced by technical causes. For this purpose the motion detector shall dispose of provisions which ensure its function.

Clause of these guide-lines	Function	VdS Class A	VdS Class B	VdS Class C
6.1	Function monitoring			
	Self test (local)	Op ^③	Op ^③	③
	Remote self test	Op ^④	Op ^④	Op ^④
6.2	Operational requirements			
6.2.1	Operating voltage behaviour	①	①	①
6.2.2	Ripple of operating voltage	Op ^②	②	②
6.2.3	Slow input voltage rise and limits of input voltage	①	②	②
6.2.4	State beyond the operating voltage	Op ^②	③	③
6.2.5	Anewed detection disposition	①	①	①
6.3	Constructional measures			
6.3.1	Reliability of parts	VdS	VdS	VdS
①, ②, ③, ④	<p>VdS-requirement corresponds with the indicated requirement for respective grade of EN 50131-BWM (Expl.: ② → VdS-requirement correspond with the requirement of EN 50131-BWM for grade 2)</p> <p>● VdS-requirement correspond with the respective requirement of EN 50131-BWM (without grade-dependant differentiation)</p> <p>Op^②, Op^③, Op^④ Optional for fulfilling the indicated grade of EN 50131-BWM Expl.: Op^② → Requirement is optional for the fulfilment of grade 2 of EN 50131-BWM</p> <p>① VdS-Requirement exceeds the respective requirement of EN 50131-BWM</p> <p>VdS Additional VdS-requirement without equivalent to EN 50131-BWM</p>			
Table 6.01 : Provisions for ensuring the functions				

6.1 Function monitoring

6.1.1 Self test

Failure and fault of programmable processing units (e. g. microprocessor) shall be indicated for motion detectors of class C.

The detector shall automatically perform at least once in 24 h a self test where security relevant functions (e. g. signal processing and evaluation) are monitored automatically as far as possible and where detected faults shall be signalled.

Alternatively, it shall be ensured that the failure of a part of the detector shall not minimise the functional reliability (e. g. redundant detector).

If normal operation of the detector is affected during a local self test, this affection shall be restricted to 30 s within a period of 2 h.

Note: For the design of interfaces see clause 8.

6.1.2 Remote self test (optional)

A detector shall perform a self test according to the requirements of table 5.02 and 6.01 within 10 s after a self test signal has been received and shall generate the associated signals and messages. Furthermore the detector shall return to normal operation at least 30 s after receipt of the self test signal.

Note: This is a requirement which is set for motion detectors of grade 4 according to EN 50131-BWM. This requirement may additionally be tested.

6.2 Operational requirements

6.2.1 Operating voltage behaviour

Nominal voltage, operating voltage range (at least nominal voltage $U_N \pm 25\%$) and maximum permitted ripple of the operating voltage shall be specified by the manufacturer. Motion detectors shall function correctly within these specified values (function test). Variations in the voltage as specified in table 6.02 shall not adversely affect the function of motion detectors.

Test	Environmental class, abbreviated description of conditions		
	I	II	III
Change of operating voltage – system voltage (B1b)	$U_N \pm 25\%$	$U_N \pm 25\%$	$U_N \pm 25\%$
Operating voltage – system voltage (B2b)	10 cycles from $U_N + 25\%$ to $U_N - 25\%$ and back	10 cycles from $U_N + 25\%$ to $U_N - 25\%$ and back	10 cycles from $U_N + 25\%$ to $U_N - 25\%$ and back
Operating voltage surge – system voltage (B2) according to EN50131-BWM	10 cycles from U_N to $U_N + 25\%$ and 10 cycles from U_N to $U_N - 25\%$	10 cycles from U_N to $U_N + 25\%$ and 10 cycles from U_N to $U_N - 25\%$	10 cycles from U_N to $U_N + 25\%$ and 10 cycles from U_N to $U_N - 25\%$

Table 6.02: Changes of operating voltage

6.2.2 Ripple of operating voltage

As a minimum requirement motion detectors shall function correctly with a voltage ripple of $\leq 1,0 V_{SS}$ if a nominal voltage of 12 V is specified. For a nominal voltage of 24 V the ripple value is $\leq 2,0 V_{SS}$. For other nominal voltages the specifications of the manufacturer shall apply.

6.2.3 Slow rise of input operating voltage and limits of operating voltage

Detectors of class B and C shall fulfil all requirements on function if the input operating voltage lies between $\pm 25\%$ of the nominal value or between the values as indicated by the manufacturer, if these are higher. If input operating voltage slowly is rised the detector shall function properly at both limit values indicated.

6.2.4 State beyond the operating voltage

If the detector is beyond the specified operating voltage as indicated by the manufacturer (loss of voltage up to total failure of the power supply) and the specified features are no more given, an alarm signal or message shall be generated for detectors of class B and C. For detectors of class C additionally a fault signal shall be generated.

6.2.5 Anew detection disposition

After generation of a signal, the detector shall be ready for detection within 10 s after the criterion that caused the signal no longer exists.

6.2.6 Operationability after application of operating voltage

The time from application of the operating voltage up to secure function of motion detectors shall be indicated by the manufacturer and shall not exceed 120 s.

6.3 Constructive requirements

6.3.1 Reliability of parts

Parts of motion detectors shall be chosen such that they correspond with the intended use in the chosen environmental class

7 Functional security and operation

In order to guarantee a secure function the following measures/documentation shall be available. The requirements according to the following table 7.01 shall apply.

Clause of these guide-lines	Function	VdS Class A	VdS Class B	VdS Class C
7.1	Constructional requirements			
7.1.2	Fastening and adjustment	VdS	VdS	VdS
7.1.3	Displays	VdS	VdS	VdS
7.1.4	Degree of protection	VdS	VdS	VdS
7.1.5	Sealability	VdS	VdS	VdS
7.1.6	Parameterisation	VdS	VdS	VdS
7.1.7	Freedom of potential, isolation resistance	VdS	VdS	VdS
7.1.8	Shielded lines	VdS	VdS	VdS
7.1.9	Strain relief	VdS	VdS	VdS
7.2	Provision of function			
7.2.1	Technical data	●	●	●
7.2.2	Mounting and installation instructions	●	●	●
7.2.3	Mounting and adjustment material	VdS	VdS	VdS
7.3	Operation			
7.3.1	Operation instructions	●	●	●
7.3.2	Adjustment elements	VdS	VdS	VdS
●	VdS-Requirement correspond with requirement according to EN 50131-BWM (without grade dependant differentiation)			
VdS	Additional VdS-requirement without equivalent in EN 50131-BWM			
Table 7.01: Survey of functional security and operation				

7.1 Constructional requirements

7.1.1 Fastening and adjustment

Motion detectors shall be designed such that they may be installed for practical use and adjusted. If special tools are required these shall be provided by the manufacturer of the devices.

7.1.2 Displays

Existing displays for operational status of motion detectors (e. g. fault) shall be unambiguous for the operator of the IAS.

Optical displays shall be visible for the operator. Acoustic displays shall have a minimum loudness of 60 dB(A) – measured according to DIN 45631 – in a distance from the warning device of 1 m.

7.1.3 Degree of protection

Motion detectors shall be designed such that at least degree of protection according to DIN VDE 0470-1 (corresponds with EN 60 529) – IP 3X is given in mounted state.

7.1.4 Sealability

Motion detectors of class B and C shall be designed such that a seal may be affixed.

7.1.5 Parameterisation

The equipment for parameterisation of motion detectors shall be designed such that the parameterisation is possible only by the installer and only with the agreement of the operator.

7.1.6 Freedom of potential, isolation resistance

The housing and all parts of housings of motion detectors shall be free of potential (except electrical protection measures). The isolation resistance shall be at least 500 kΩ.

7.1.7 Shielded lines

Motion detectors shall be designed such that for shielded lines the shields may be connected in a secure manner.

7.1.8 Strain relief

Connection elements and points of cables and wires are to be relieved from mechanical strains if such strains may be anticipated.

7.2 Disposition of function

7.2.1 Technical data

Technical data shall be provided in German language for motion detectors. These shall contain all parameters necessary for a secure operation of the motion detector.

7.2.2 Mounting and installation instruction

Mounting and installation instructions shall be made available in German language for motion detectors. These shall contain a clear scheme of the mounting and installation process and the note for which applications the motion detector is suitable. Furthermore indications for adjustment (justage) and maintenance are necessary. Adjustments which are not admitted shall be identified unambiguously.

At least the following documentation shall be available:

- A list of all options, functions, inputs, signals or messages, displays and their essential features;
- A scheme of the detector and the shown detection boundary, top view, side view in a height of 2 m or a height indicated by the manufacturer, superimposed with a square grid with 2 m edge length elaborated by the manufacturer. The size of the grid shall refer directly to the size of the detection boundary as indicated by the manufacturer;
- Recommended mounting height and effects of changes of this height on the indicated detection boundary;
- Effects of adjustable elements on the detection performance of the detector or its indicated detection boundary including at least minimum and maximum adjustments;
- All inadmissible adjustments which are possible on site and corresponding combinations;
- All specific adjustments which are necessary to fulfil the requirements of the present European standard for the grade as indicated by the manufacturer;
- If operating elements are available for orientation these shall be marked such that their function is identifiable;
- A warning note for the user that the field of view of the detector shall neither partly nor completely be obstructed;
- Nominal voltage as indicated by the manufacturer and maximum and quiescent current at this voltage;
- If given – all special requirements which are necessary for detection of a reduction of range of 50 %;
- Mounting material and adjustment aids.

If special mounting material is required for the mounting of motion detectors, this shall be made available by the manufacturer. If an adjustment of motion detectors may be made with technical equipment the manufacturer shall make respective adjustment aids available to the installer.

7.3 Operation

Operations to be performed by the operator shall be possible in an easy manner. Displays shall be designed in a clear and understandable way.

7.3.1 Operating instructions

Operating instructions shall be available in German language for the operator of the IAS. The instructions shall contain a clearly arranged scheme and description of all operating and display elements which are important for the operator and unambiguous instructions for all operating statuses of the system.

7.3.2 Adjustment elements

The manufacturer shall indicate all detection features of the motion detector for all extreme parameters. If several adjustment elements are existing the functions and effects of these elements shall be described.

If motion detectors have only an electrical adjustment element (e. g. range) the position "nil" (i.e. no function) shall not be possible. Adjustments performed shall be traceable such that a deviation of 20 % at maximum occurs.

Note: The requirements on environmental behaviour according to clause 8 shall be kept in all possible adjustments. Requirements on immunity against false alarms shall be fulfilled for the adjustments indicated by the manufacturer in all respective cases.

8 Interface to the intruder/hold-up alarm system

Interfaces to other system components, e. g. control and indicating equipment, shall be designed such that a proper function is ensured. Depending on design of the detector and the other system component a common test may be necessary.

The interfaces shall be described in all details by the manufacturer. Alternatively the interfaces indicated in clause 8.1 may be used.

Note: A detailed description of the interfaces may be omitted only if all requirements of clause 8.1 are fulfilled.

Clause of these guide-lines	Function	VdS Class A	VdS Class B	VdS Class C
8.1	Interface for conventional line technology			
8.1.1	Inputs	VdS	VdS	VdS
8.1.2	Outputs	VdS	VdS	VdS
VdS additional VdS requirement without equivalent in EN 50131-BWM				
Table 8.01: Interfaces				

8.1 Interface for conventional line technology

The following requirements for inputs and outputs are valid for IAS with external power supply of the detectors and a conventional line technology (end-of-line resistor):

8.1.1 Inputs

8.1.1.1 Operating voltage

Motion detectors shall dispose of connecting elements for the power supply.

8.1.1.2 Switch on/off of function display according to clause 5.7.2

Class A

If the function display may be switched on/off then its design shall correspond with class B and C.

Class B and C

For function test of the detectors performed by the operator, an input for switch on/off of the function display shall be available, which is to be configured according to table 8.02.

	Display active (input LOW or logical 0)		Display inactive (input HIGH or logical 1)	
	Minimum	Maximum	Minimum	Maximum
Input voltage	0 V	1,5 V	3,5 V	U_{Bmax}

Table 8.02: Input for switch on/off of the function display

8.1.1.3 Operating modes

For switching on/off of existing operating modes, inputs shall be available which are to be configured according to table 8.03.

	Operating mode active (input LOW or logical 0), e. g. emitter switched on; motion detector fully operational, storage released (IAS in set status)		Operating mode inactive (input HIGH or logical 1)	
	Minimum	Maximum	Minimum	Maximum
Input voltage	0 V	1,5 V	3,5 V	U_{Bmax}

Table 8.03: Input for switching on/off of the operating modes

8.1.1.4 Additional inputs

The respective values shall be indicated by the manufacturer.

8.1.2 Outputs

8.1.2.1 Interface for intruder signals

The interface shall fulfil the following conditions:

- Potential free output, load capacity at least 50 mA at 30 V=; resistance in row $\leq 47 \Omega$
- Closed in idle state (low resistive), opening in the event of a signal (high resistive)
- response time ≥ 1 s to ≤ 10 s, the contact shall close/the output shall become low resistive no later than 10 s after the end of the criterion triggering the alarm
- facility for connecting a monitoring element (e.g. end-of-line resistor)

8.1.2.2 Additional electronic output for intrusion signals (optional)

This is to be designed as open-collector-output which is to be configured according to table 8.04 and 8.05.

	Idle state	
	Minimum	Maximum
Output voltage	-	Depending on U_B
Output current	-	Depending on U_B
Leakage current	-	$\leq 50 \mu A$

Table 8.04: Output for intrusion signals, idle state

	Signal	
	Minimum	Maximum
Output voltage	-	1,5 V
Output current	1 mA	Depending on U_B

Table 8.05: Output for intrusion signals, signalling state

8.1.2.3 Interface for tamper signals

Class A

No requirements.

Note: If given, the interface should correspond with the requirements for classes B and C.

Class B and C

The interface shall fulfil the following conditions:

- Potential free output, load capacity at least 50 mA at 30 V=; resistance in row $\leq 47 \Omega$
- Closed in idle state (low resistive), opening in the event of a signal (high resistive)
- response time according to the time of response for a tamper signal

8.1.2.4 Interface for signals of function monitoring

Class A and B

If given, design according to class C.

Class C

The interface shall fulfil the following conditions:

- Potential free output (relay), which disposes of a closed contact in normal state, of an opened contact in case of fault.
- response time at least 1 s, at maximum according to the time of fault

8.1.2.5 Additional outputs

The respective values shall be indicated by the manufacturer.

8.2 Interface for other technologies

The characteristics shall be specified by the manufacturer.

9 Protection against environmental influences

9.1 Limits of application

Environmental influences shall not affect the function of motion detectors. Environmental influences can have various effects on operating characteristics, depending on the nature of the function applied. The manufacturer shall therefore specify the limits of the application (e.g. climates). The requirements and test methods as described in the Guidelines

for Intruder Alarm Systems, Protection against Environmental Influences (VdS 2110) are to be applied. A summary of requirements and test methods is given in the following:

Type of conditioning	Group	EN 50130-4	EN 50130-5	Additional or other specification
Climates	T			
Dry heat			●	
Cold			●	
Damp heat			●	
Change of temperature			●	
Sun radiation			☞ ^a	
Water and debris	F			
Water ingress			●	
Dust-proven			●	
Debris			☞	EN 60 529
Corrosion	K			
Corrosion SO ₂			☞	DIN EN ISO 6988
Salt mist			●	
Corrosion window cleanser				VdS
Mechanical conditioning	M			
Shock			●	
Jolt			☞	VdS
Impact			●	
Vibration			●	
Free fall			●	
Operating voltage conditionings	B			
Change of operating voltage/bumps		●		
Electromagnetic compatibility	E			
electrostatic discharge		●		
Radiated high frequency		☞		VdS
Conducted radio frequency		●		
Conducted electrical fast transient (Burst)		●		
Conducted electrical slow transient (Surge)		●		
<p>☞ VdS requirement exceeds the respective requirement of EN 50130-4 resp. EN 50130-5</p> <p>● VdS requirement corresponds with the requirement of EN 50130-4 resp.. EN 50130-5</p> <p>VdS Additional VdS requirement without equivalent in a European standard</p> <p>^a For motion detectors according to these guidelines (see clause 9.2)</p>				

Table 9.01: Environmental influences

9.2 Climates (sun radiation)

A long-term influence by direct or indirect light shall not lead to changes of the performance features of motion detectors.

10 General conditions and test conditions

10.1 General

The tests are mainly intended to check the correct function of the detector against the specification as presented by the manufacturer. All defined test parameter shall basically lay within the limits of $\pm 10\%$, if not indicated otherwise. A list of tests is shown as general matrix in annex B.

10.2 Conditions

10.2.1 Environmental conditions for tests

Unless otherwise specified all tests are performed at the following environmental condition.

Temperature 15 ...35° C

Relative humidity 25 % up to 75 % RH

Air pressure 860 -1060 hPA

10.2.2 Test assembly

Tests are performed only at completely installed and functionable system components. The assembly and – if given – the necessary adjustment is made according to the installation and mounting instructions of the manufacturer.

The connections which are necessary for the function tests (e. g. displays) shall be available or be simulated. On deviations of this may be agreed in single cases.

10.2.3 Number of specimen

Ten complete motion detectors including eventually necessary mounting material are required for the tests. The test schedule for the respective samples is described in annex B.

10.2.4 Documentation

The following documentation is required for the tests:

- Technical data
- Circuit diagram
- Parts list
- Assembly diagrams, layouts
- Description of fundamental functions
- Installation and mounting instruction
- Operating instruction (if necessary)
- If given data sheets of relays, switches and other parts

10.3 Determination of test extent

If motion detectors may fulfil other functions e. g. after reprogramming than the pre-described requirements (see clauses 5 to 9), it shall be determined in detail before testing in which status (programming) the test shall be performed.

If special constructions or new overriding methods of motion detectors render necessary additional tests, these are to be agreed with the manufacturer and to be performed.

10.4 Test methods

The detector is to be mounted in a height of 2,0 m if not otherwise specified by the manufacturer. The direction shall correspond with the indications of the manufacturer with an unobstructed view on the walk test to be performed. The detector is to be connected to nominal voltage and to a monitoring system for signals and messages. For the stabilisation of the detector 180 s are to be granted. If several sensitivity modes as (pulse counting) are possible, all modes that do not fulfil the requirements shall be indicated by the manufacturer. All other modes shall be tested.

10.5 Basic detection test

The purpose of the basic detection test is to verify that a detector is still operational after a test or tests has/have been carried out. The basic detection test verifies only the qualitative performance of a detector. The basic detection test is performed using the BDT.

10.5.1 Basic detection target (BDT)

The passive infrared BDT consists of a heat source with heat emission equivalent to that of a human hand, which can be moved across the field of view of the detector. An informative description is given in Annex E. The temperature of the source shall be between 3,5° C and 10,0° C above the background temperature.

The microwave BDT shall be a metal plate which reflects microwave emission and which can be moved across the field of view of the detector.

The ultrasonic BDT shall be a metal plate which reflects ultrasonic emission and which can be moved across the field of view of the detector.

BDTs may be used separately or together.

A close-in walk test may be carried out as an alternative to using the BDT.

10.5.2 Basic test on detection capability

A stimulus that is similar to that produced by the BDT is applied to the detector using the BDT. The BDT for detectors with passive-infrared technology is moved perpendicularly across the centre line of the detection field at a distance of not more than 1 m and at a height where the manufacturer claims detection will occur.

The BDT is moved at a distance of 1 m at a velocity of 0,5 ms⁻¹ to 1,0 ms⁻¹.

For motion detectors which are based on microwave or ultrasonic technology the BDT is moved at a distance of 2 m up to a distance of 1 m of the detector and at a height where the manufacturer claims detection will occur.

The detector shall generate an intrusion signal or an intrusion message when exposed to an alarm stimulus both before and after being subjected to any test that may adversely affect its performance.

Note: For detectors where passive-infrared and microwave or ultrasonic technologies according to EN50131-BWM are combined, the basic detection test may be performed with the passive-infrared part of the detector and the respective other used detector part (microwave or ultrasonic) separately. For this purpose one part of the detector is activated whereas the device shall not generate an intrusion signal or an intrusion message. The other detector part is tested at the same time with the respective basic detection target.

11 Receiving controls

11.1 Check on completeness

It is checked if

- Motion detectors are handed in for testing in correct design and completely equipped and - if given – necessary connections are available
- The annexed technical documentation is in German language, complete and sufficient for the testing
- Eventually associated mounting material is available

11.2 Test on basic functions

Following basic functions are checked in detail.

- Detection function by walk tests of a person with a velocity of $V = 1\text{m/s}$
- Detection range
- Indication and record functions (if given)
- Function of tamper monitoring (if given)
- Current consumption depending of operating voltage U_B

11.3 Test on adjustment values

It is checked if all adjustment values (e. g. calibration values) are set according to the adjustment instruction. Potentially differing values are corrected.

11.4 Initial running

The test specimen are operated for at least 24 h at room temperature with correct adjustment after which all adjustment parameters are checked on inadmissible deviations.

Note: If during initial running inadmissible deviations are occurring, it shall be clarified from case to case if the test is continued.

11.5 General tests

11.5.1 Marking

A visual check is made in order to verify if the test specimen disposes of a company's name and type marking. The marking shall unambiguously show who has manufactured the device resp. who distributes it and which type of device it is.

A visual check is made in order to verify if the test specimen disposes of a serial marking which shall not be visible once the device is properly installed. The serial marking shall show in which period (month and year) the motion detector has been manufactured. In case of coded marking the manufacturer shall define in writing the marking.

A visual check is made in order to verify if the marking of the test specimen as VdS-approved corresponds with the requirements (see VdS 2344) and if the marking is affixed at a point which is easily accessible. The marking and/or identification shall be affixed at the product according to the requirements of EN 50131-1.

Note: For this purpose a re-examination after finalising of the approval procedure may become necessary.

Pass/fail criteria: The test is passed if all markings are affixed in a sufficiently solid manner.

11.5.2 Safeness for users

A visual check and a function check is performed (requirements see VdS 2227) in order to verify if system components are designed such that no risks occur for the operator (e. g. sharp edges) in use.

11.5.3 Requirements by authorities

It is checked if necessary licences by authorities are available.

12 Test of function

12.1 Response behaviour

For the performance of the following tests the detectors are mounted in a room in which preferably no negative influences will occur on the detector (e.g. no air flow).

For the testing of motion detectors with infrared technology furthermore the temperature of the environment, of the background as well as the surface of the test person are measured and recorded. The temperature difference between test person and background shall at least be 3 K. If several sensitivity modes, e. g. by using pulse counter, are available, all modes which do not fulfil the requirements shall be indicated by the manufacturer. All other modes shall be tested.

12.2 Conditions for walk tests according to EN 50131-BWM

For the performance of walk tests in the context with EN 50131-BWM the test person and the test room for the walk test shall lay within the following specifications:

12.2.1 Walk test target (test person)

The test person identified as walk test target (SWT) shall have a body height of 160 cm up to 185 cm and a weight of 70 kg \pm 10 kg, wearing close-fitting clothes and a heat emission value of more than 80 % in the wave length range of 8 μ m up to 14 μ m.

Temperatures shall be measured at the following five points at the front body side of the SWT:

1. Head
2. Chest
3. Back of the hand
4. Knee
5. Feet

The temperature shall be measured with a contactless thermometer or an equivalent device.

This person shall remain before the test a longer time in the test room so that the clothes may adapt to the room temperature. The temperature differences of each body point against the background temperature are measured, weighted and then the values are averaged, as described in detail in annex C .

Means for calibration and control of the required velocity with which the SWT is to move should be available (see annex D).

Note: Instead of a walk test target in form of a test person the use of a simulator/robot is allowed if the requirements of the walk test target regarding temperature are fulfilled. This is named simulated target (simulated walk test target). In case of doubt primary reference shall be the walk test performed by a person.

12.2.2 Temperature differences of the standard walk test target

The walk tests shall either be performed at a medium temperature difference Dt_r (as described in C.1) of $3,5\text{ ° C} \pm 20\%$. If the temperature difference Dt_r is higher than $3,5\text{ ° C} + 20\%$ ($4,2\text{ ° C}$) this may be adopted with one of the means as described in C.2 in order to receive an adequate temperature difference Dt_e .

If Dt_r is less than $3,5\text{ ° C} - 20\%$ ($2,8\text{ ° C}$) a valid test is not possible.

If Dt_r lies between $2,8\text{ ° C}$ and $4,2\text{ ° C}$ no adjustment is necessary.

12.3 Walking without interruption

The test specimen is mounted, connected and set in **functional state** to a supply and processing unit according to the manufacturers instructions.

The tests of the detectors are made with the adjustments that are admitted by the manufacturer (e. g. sensitivity) according to the installation instructions. The tests are to be repeated at least for the minimum, the maximum and medium possible adjustments.

A grid with widths of 2 m x 2 m at maximum with the respective diagonals is to be traced on the floor of the test room (see figures 12.01 and 12.02). For the respective test the detection range of the detector as indicated by the manufacturer is traced on the floor of the test room.

The respective velocities and attitudes that the test person (standard walk test target) is to keep are defined in table 5.03. The deviations admitted for the velocities are $\pm 10\%$. A pulse generator (e. g. metronome) for the second pulsing as well as a time clock serve as test equipment (see also annex D).

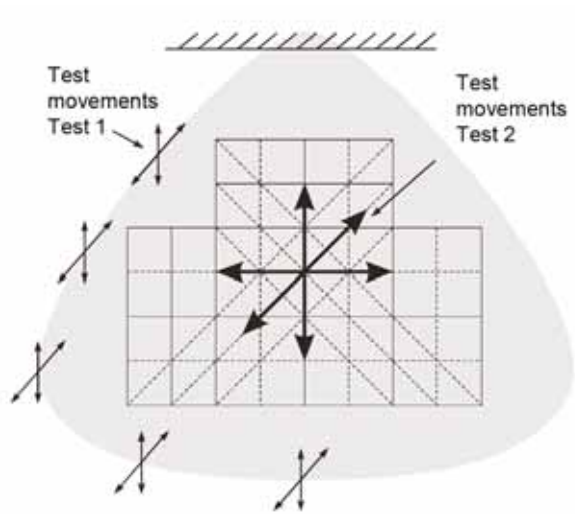

Figure 12.01: Testing of the detection range of microwave and ultrasonic detectors

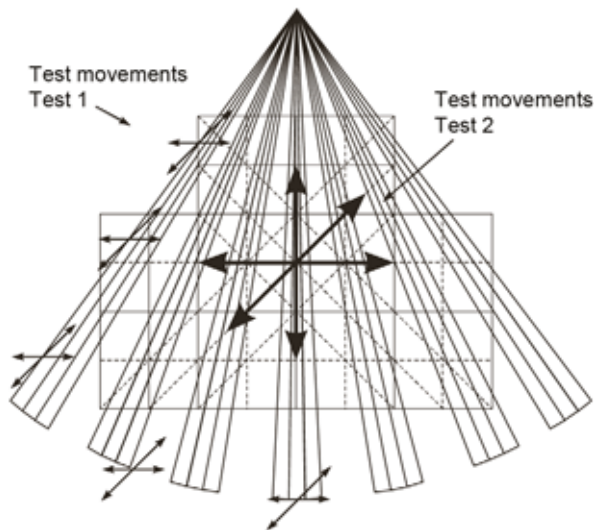

Figure 12.02: Testing of the detection range of an infrared motion detector

The following tests are performed:

Test 1

By walking movements with a velocity of approx. 1 m/s from the outside of the detection range in direction to the detector, the boundary of detection is determined. Test points are placed at 2 m intervals at the boundary line of the detection pattern, starting from the detector and finishing where the boundary line crosses the detector axis. This is repeated for the opposite side of the detection pattern. If the gap between the final point on each side is greater than 2 m, a test point is placed where the boundary crosses the detector axis. Each test point is connected to the detector by a radial line. At each test point two test directions towards the detection coverage pattern are available at + 45° and -45° along with the radial line. Both directions shall be tested beginning at a distance of 1,5 m from the test point, and finishing 1,5 m after it.

A walk test is a walk in one direction crossing the test point. Before commencing and after completion each walk test, the standard walk test target (SWT) shall stand still for at least 20s.

Test 2

Starting at the detector, a first test point is placed in a distance of 2 m along the detector axis. Using the 2 m squared grid, further test points are placed at every next grid intersection. No test point shall be less than 1 m from or lie outside the claimed detection boundary.

At each test point two test directions are available, at + 45 ° and -45° along the radial line. Both directions shall be tested with a velocity of 1 m/s beginning at a distance of 1,5 m from the test point and finishing 1,5 m after it.

A walk test is a walk in one direction crossing a test point. Before commencing and after completion each walk test the SWT shall stand still for at least 20 s.

Test 3

By a slow motion – for detectors of class A with 0,3 m/s, of class B with 0,2 m/s, class C with 0,1 m/s – at least 100 walking movements are performed with upright attitude of the test person (standard walk test target) in parallel to the detector, in an angle of 45°, at right angle to the detector (see figure 12.03) resp. directly towards the detector and from the detector away in an angle of 45 ° to the detector (see figure 12.04) over a distance of each 2 m.

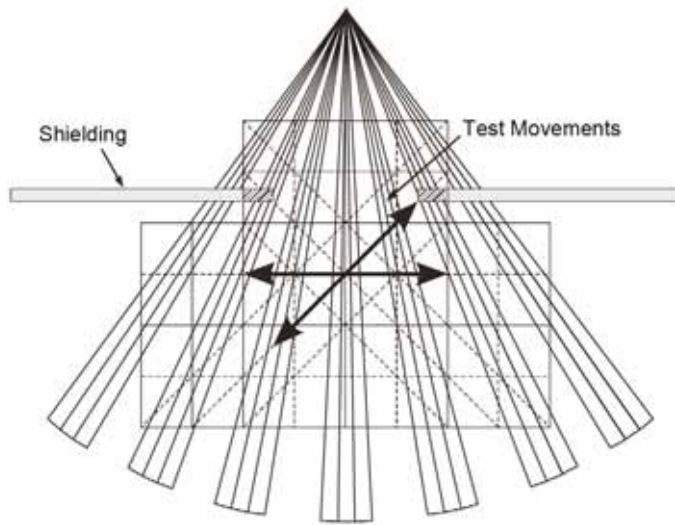

Figure 12.03: Testing of the response behaviour of infrared motion detectors

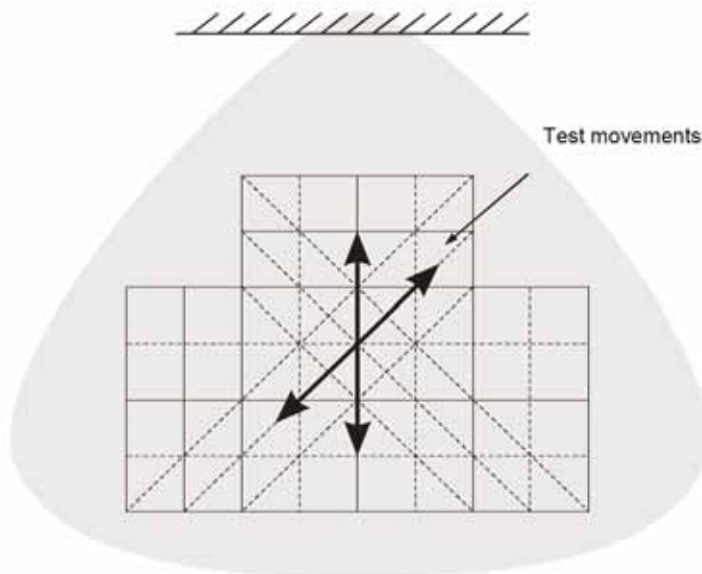

Figure 12.04: Testing of the response behaviour of ultrasonic and microwave motion detectors

Test 4

Four walk tests are performed. Two walk tests begin outside the detection boundary from opposite sides, and pass through the detector axis mid-range point at +45° and -45° to the detector axis, moving towards the detector. The third and fourth walk test passes at right angle to the detector axis at a distance of 2 m in front of, and parallel to the detector reference line. The walk test target shall cross the complete detection area and coming to rest after clearing the other detection boundary.

Additionally the test is repeated in analogy with test 3 whereas at least 30 % of the test points of test 3 are explored.

Following walking velocities shall be used:

For **classes A and B**: 3 m/s

For **class C**: 4 m/s

Test 5

Two walk tests are performed which each begin and end outside the detection boundary. The walk tests are performed with the velocities as indicated in table 5.03 at the distance of $2\text{ m} \pm 0,2\text{ m}$ (for classes A and B) as well as $0,5\text{ m} \pm 0,05\text{ m}$ (for class C). The distance value refers hereby to the distance between detector and the middle of the test person (standard walk test target) on the middle vertical axis of the detector.

The test person (SWT) shall cross the complete detection area and come to rest after clearing the other detection boundary.

Test 6

For detectors of class A the test is repeated in analogy to test 3 in ducked attitude with a velocity of 0,3 m/s at least 20 times. The test shall be performed only in the vicinity of the detector (30 % of the detection range at maximum). For detectors which dispose of a special feature (e. g. immunity against small animals) the test is performed up to the maximum nominal detection range.

Test 7

For detectors of classes B and C the test is repeated in analogy to test 3 in crawling attitude with a velocity of 0,3 m/s 10 times at maximum. This tests is performed only in the vicinity of the detector (up to 30 % of the detection range as indicated by the manufacturer).

For detectors which dispose of a special feature (e. g. immunity against small animals) the test is performed up to the maximum nominal detection range.

Test 8

For detectors of class B and C the test is repeated in analogy to test 3 in crawling attitude with a velocity of 1 m/s 10 times at maximum. This test is performed only in the vicinity of the detector (30 % of the detection range at maximum).

For detectors which dispose of a special feature (e. g. immunity against small animals) the test is performed up to the maximum nominal detection range.

Within the detection areas each signal shall be triggered after a distance of 2 m at the latest.

For test 1 and test 2 the following is applicable: A walk test attempt which generates an intrusion signal or message, is a passed walk test. Alternatively if the first walk test attempt does not generate an intrusion signal or message then four further attempts shall be carried out. All of these further attempts shall generate an intrusion signal or message to constitute a passed walk test.

Pass/fail criteria: For each test point a passed walk test in both directions shall be available. For the totality of walk tests is additionally valid that the response probability is determined from the results of all performed tests. It is checked if for all tests the movements lead to signalling with a probability of 70 % for class A, of 80 % for class B and of 90 % for class C.

12.4 Walking with intermittent movement

The standard walk test target (test person) moves in a distance of the detector of approx. 25 % and 75 % of its respectively adjusted detection range with a velocity of approx. 1 m/s upright in an angle of +45° and -45° to the detectors axis in direction of the detector (see figures 12.01 and 12.02). The person is moving for 1 s, then stops for 5 s and continues its movement, and so on.

The detection shall be triggered at least after 5 m distance made or at least, when 50 % of the distance between the starting point of the movement and the detector is made.

Pass/fail criteria: For each test point a passed walk test in both directions shall be available.

12.5 Immunity against unwanted alarms

12.5.1 General

For testing the immunity against unwanted alarms, the following tests are performed that are representative for the false alarms sources as existing in practical experience.

If not stated otherwise in the following, the specimen will be prepared before testing as follows:

The specimen is mounted in a room according to the manufacturers specifications, shall be connected and set in operational status to a supply and processing unit. The adjustments of the detector (e. g. sensitivity) is made according to the manufacturers indications in the installation instructions such that a maximum sensitivity against interferences is given (e. g. maximum sensitivity, minimal pulse counting). If appropriate, the tests shall be repeated for different adjustments.

12.5.2 Exceeding the specified detection area

In connection with the test on the detection range it is checked if the detection range of the detector as indicated by the manufacturer is not exceeded by more than 30 % at any point.

For this purpose the walking tests are performed outside of the detection range of the detector in a radial distance of the detector, which exceeds the distance to the boundary of the detection range by 30 %.

Pass/fail criteria: The state of the detector shall not change.

12.5.3 Movement of small objects in the detection range

For the following tests flakes in oval and waved form of expanded polystyrene (e. g. styrofoam) with dimensions 30 mm x 20 mm are used.

In a distance of 1 m in front of the detector approx. 0,5 m above the detector is a case, from which the flakes are dropped (see figure 12.05).

Initially only few flakes are dropped, later up to 10 flakes are dropped at the same time. During exposure not change of state shall occur (e. g. no signal).

Pass/fail criteria: The state of the detector shall not change.

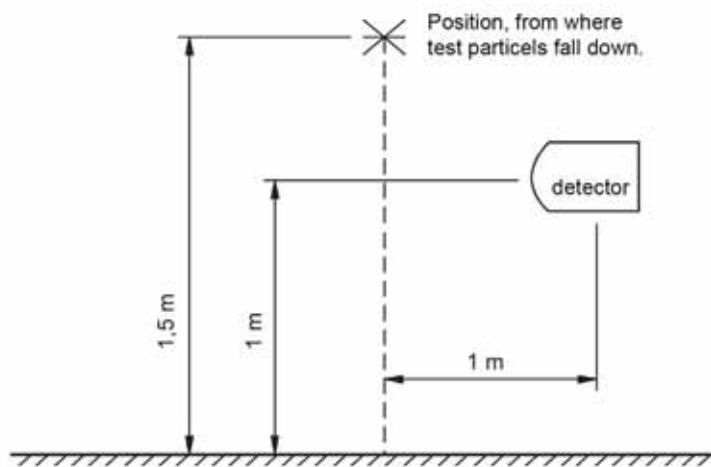

Figure 12.05: Test with small objects in the detection range

By a second test where the detector is objected to this test and at the same time a walk test according to Test 2 in Clause 13.2 on two centre points of the detection range it is ascertained if the detector is not blocked by the exposure.

Pass/fail criteria: The test is passed if the detector generates an intrusion signal or an intrusion message.

12.5.4 Movements of small objects on the floor of the detection range

For the following test a brass round stock with a length of 150 mm and a diameter of 30 mm is used as small object.

The object is warmed up to a temperature of 6° C ($\pm 2^\circ$ C) above the temperature of the floor and moved with a velocity of 0,5 m/s ($\pm 20\%$) according to figure 12.06 across the detection range

- In an angle of each 45 ° to the detectors vertical axis and
- In parallel in a distance of 1 m and 2 m to the detector
- On the detectors vertical in direction towards the detector resp. from the detector away

All movements shall start outside the detection range wherever possible.

The distance of the object to the floor shall not exceed 200 mm.

Pass/fail criteria: The state of the detector shall not change.

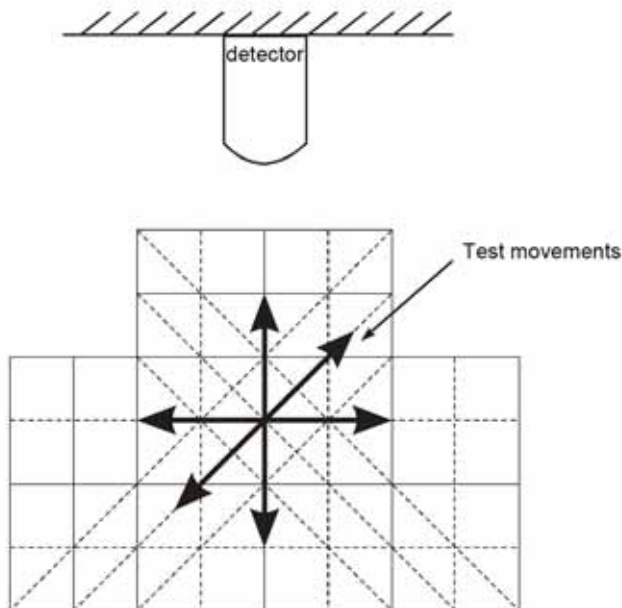

Figure 12.06: Test with small objects on the floor

12.5.5 Movement of small objects in the inside of the detector

Initially the detectors technology is evaluated if false alarms that are caused by small objects entering in the detector (e. g. beetles, spiders) may be excluded.

If false alarms may be anticipated, it is evaluated on base of the available construction if small objects with a diameter of ≥ 3 mm may enter into the inside of the detector. If this is possible, the detector has failed the test. If the entering, however, is not possible or only partly, the test as described in the following is continued.

The detector is opened and several steel balls with diameter 2 mm are put in critical zones of the detector (e. g. sensor area for infrared motion detectors). The detector then is reassembled properly. By change of position and by vibration it is checked if the steel balls may drop out of the detectors inside.

Pass/fail criteria: The test is passed if no steel ball drops out of the detector.

12.5.6 Oscillating movements in the detection range

Note: This test is not applied to infrared motion detectors.

The following objects are used for this test:

- Stable paperboard container (approx. 300 g/m²) with dimension of approx. 250 mm x 500 mm
- Heavy curtain drapery with dimension of approx. 400 mm x 2000 mm
- Light curtain drapery with dimension of approx. 400 mm x 2000 mm

These objects are positioned each according to figure 12.07 in a distance of 75 % of the adjusted detection range of the detector with their space centred to the detector.

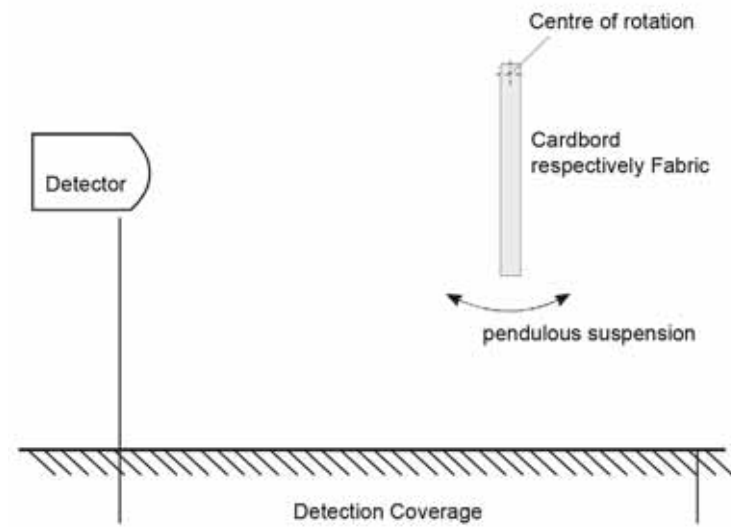

Figure 12.07: Test with oscillating objects

The objects are each deflected by approx. 50 mm and then dropped. It shall be ensured that the objects may swing freely. The test is repeated five times per object.

Pass/fail criteria: The state of the detector shall not change.

By a second test where the detector is objected to this test and at the same time a walk test according to Test 2 in Clause 13.2 on two centre points of the detection range it is ascertained if the detector is not blocked by the exposure.

Pass/fail criteria: The test is passed if the detector generates an intrusion signal or an intrusion message.

12.5.7 Light radiation

A car head lamp, H4 bulb light is simulated for this test. For this purpose

- a light source with a H4 bulb light, 12 V/60 W according to IEC 60 809 with a life cycle of at least 10 h and 100 h at maximum, connected to a 13,5 V \pm 10 % d.c. power supply
- as a reflector a round car head lamp without diffusion disk
- as simulation of the glazing a clean silicate glass pane, thickness 4 mm

are used.

Detector, glass pane and light source are mounted according to figure 12.08. The light source hereby is positioned in approx. 5 m distance to the detectors vertical axis and oriented to the detector such that this is evenly illuminated. Between light source and detector in the middle and in right angle the properly cleaned glass pane is inserted.

By slight change of the distance the luminance intensity at the detector is adjusted to 6500 lx (\pm 15 %).

Detectors which dispose of different sensitive points within the detection area (e. g. infrared motion detector) are first oriented such that the light radiation occurs from the most sensitive point (test 1); the orientation then is changed such that the light radiation from outside of this sensitive point resp. from outside the detection range occurs (test 2).

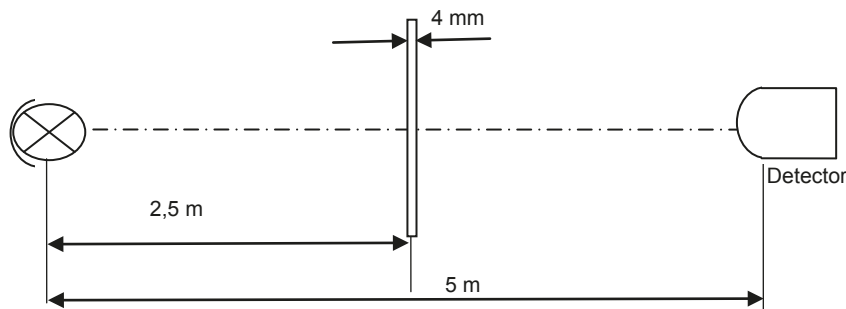

Figure 12.08: Test with light radiation

The tests are performed as follows:

Test 1

Within the most sensitive point of the detection area (e. g. in a zone which is sensitive to infrared) a light source is switched on and off in total five times for 2 s. The light source is then moved in total five times such that the detectors is illuminated for 2 s and for 2 s not illuminated.

Test 1a

If test 1 leads to triggering of the detector a second glass pane is positioned before the light source and the test is repeated.

If still then a triggering is effected, test 2 is performed.

Test 2

Exterior of the most sensitive point of the detection area a light source is switched on and off in total five times for 2 s. The light source is then moved in total five times such that the detectors is illuminated for 2 s and for 2 s not illuminated.

Test 3

Additionally the test 1a is repeated whereas the light source is moved over a vertical axis such that the radiated light crosses the detector with a velocity of $0,5 \text{ ms}^{-1}$ and moves over the exterior area of the detectors housing. In total 10 movements are performed over the front side of the detector.

Test 4 (only for **combined** detectors with passive infrared and either ultrasonic or microwave technology).

The ultrasonic technology (for combined passive infrared and ultrasonic detectors) or the microwave technology (for combined passive infrared and microwave detectors) are placed in a condition where the PIR-part may trigger an intrusion signal or an intrusion message. Then the tests 1a and 2 are repeated.

Note: Depending on the test result it may be decided upon restrictions for future application of the detector.

Pass/fail criteria: The state of the detector shall not change.

By a second test where the detector is objected to this test and at the same time a walk test according to Test 2 in Clause 13.2 on two centre points of the detection range it is ascertained if the detector is not blocked by the exposure.

Pass/fail criteria: The test is passed if the detector generates an intrusion signal or an intrusion message.

12.5.8 Light sources in the detection area

A light is positioned in the detection area of the detector for the following test. The light consists of two standard fluorescent lamps which are mounted on a white space parallel in a distance of 100 mm (without any cover, without diffusion disk, without reflector).

The fluorescent lamps have the following parameter:

- Performance 58 W
- Length 1,50 m
- Diameter 26 mm
- Life cycle between 100 h and 1000 h

Test 1

The lamp is positioned according to figure 12.09 in a distance of 2 m before the detector and 0,5 m above the detector in parallel to the detector axis (test direction B) as well as vertically to the detector axis (test direction A). The supply is effected with a voltage of 230 V ($\pm 10\%$), 50 Hz.

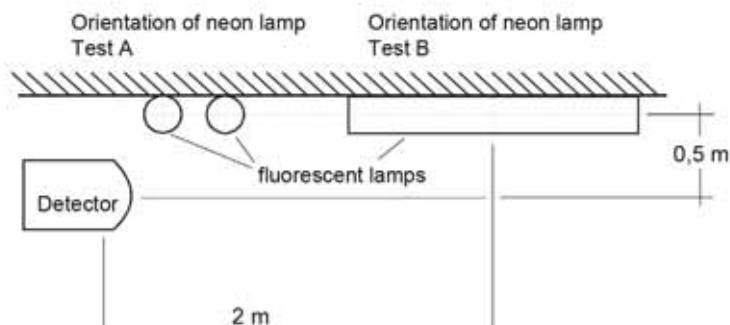

Figure 12.09: Test with fluorescent lamps

The lamp is switched on for 60 s and off for 30 s each five times when being positioned in cross line and in parallel.

Pass/fail criteria: The state of the detector shall not change.

A test on the basic functions is performed using the basic detection target in order to determine if the detector is not influenced by the test with the fluorescent lamp.

Pass/fail criteria: The test is passed if the detector generates an intrusion signal or an intrusion message.

Test 2 (only for **combined** detectors with passive infrared and microwave technology)

The passive infrared technology of the detector is set in a condition where the microwave technology may generate an intrusion signal or an intrusion message. Then test 1 is repeated.

Pass/fail criteria: The state of the detector shall not change. By a second test where the detector is objected to this test and at the same time a walk test according to Test 2 in Clause 13.2 on two centre points of the detection range it is ascertained if the detector is not blocked by the exposure.

Pass/fail criteria: The test is passed if the detector generates an intrusion signal or an intrusion message.

12.5.9 Air flows and turbulences

Standard roll fan heaters with the following technical parameters are used for this test:

- Performance 2000 W
- Dimension of fan opening approx. 55 mm x 180 mm
- Velocity of the releasing warm air v_1 of approx. 2,2 m/s
- Angle of release over horizontal approx. 12°

Test 1

The fan heater is positioned according to figure 12.10 in front of the detector and adjusted such that the maximum air flow is given a the detector (v_2 of approx. 0,7 m/s).

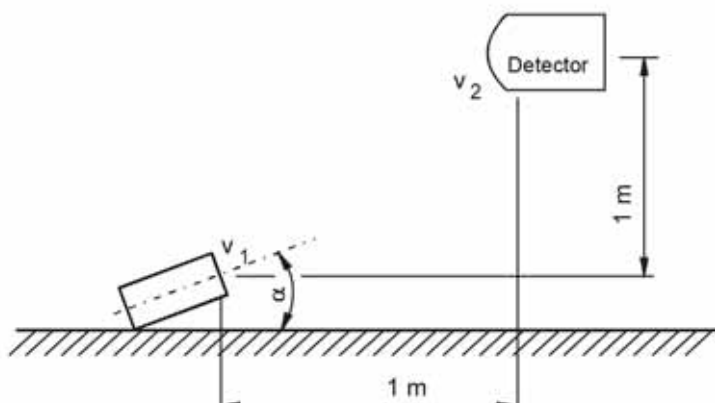

Figure 12.10: Test with air flow

The detector is subjected first the warm air for a duration of 60 s, then the fan heater is switched on and off for each 5 s.

Test 2 (only for combined detectors with passive infrared and ultrasonic technology)

The ultrasonic part is placed in a condition in which the PIR part may generate an intrusion signal or an intrusion message. Then test 1 is repeated.

Pass/fail criteria: The state of the detector shall not change.

By a second test where the detector is objected to this test and at the same time a walk test according to Test 2 in Clause 13.2 on two centre points of the detection range it is ascertained if the detector is not blocked by the exposure.

Pass/fail criteria: The test is passed if the detector generates an intrusion signal or an intrusion message.

12.5.10 Extraneous sound sources

A standard white noise generator operating between 20 Hz and 30 Hz is used. This shall be mounted at a distance such that it produces at 26,3 Hz a nominal sound pressure level of 86 dB (1µPa) ± 2 dB (1 µPa) at the detector.

Test 1

The generator is switched on for 60 s and then switched off for 180 s. This cycle shall be repeated five times.

Test 2 (only for combined detectors with passive infrared and ultrasonic technology)

The PIR part is set in a condition in which the ultrasonic part may generate an intrusion signal or an intrusion message. The test 1 is repeated.

Pass/fail criteria: The state of the detector shall not change.

By a second test where the detector is objected to this test and at the same time a walk test according to Test 2 in Clause 13.2 on two centre points of the detection range it is ascertained if the detector is not blocked by the exposure.

Pass/fail criteria: The test is passed if the detector generates an intrusion signal or an intrusion message.

Finally a test on the basic function is performed by the BDT in order to ascertain if the detector is still operational.

12.5.11 Immunity against false masking

The standard walk test target (test person) shall perform a walk test in a distance of 1 m within the detection range with a velocity of 0,5 m/s and with a velocity of 1 m/s.

Pass/fail criteria: The test is passed if the detector does not generate a masking signal or a masking message.

12.6 Overriding by bypassing the monitoring method

The test is performed per technology and in connection with the test on tamper monitoring and the suppression of faults. A test person tries e. g. at ultrasonic motion detectors to bypass the fault suppression by oscillating movements of its arms or by walking forward or backward.

The practical simulation of environmental influences and faults shall not essentially impair the detection features of the detector.

Pass/fail criteria: The test is passed if the detector shows no negative influences of its detection performance despite the movements generated by the test person.

12.7 Triggering identification

It is checked if the motion detector is connected to the IAS such that the operator is able to identify which detector has triggered.

Note: This may be realised either by connection of one detector to an alarm point or by displays in detectors, including storage function. The design of displays is tested according to clause 14.1.2.

Then it is checked if it is ensured after a triggering of a detector that the information on the triggering of the detector is not falsified in unset state of the IAS (e. g. when entering the protected premises after unsetting).

It is checked if the deletion of this information is possible also for the operator (e. g. by operation function a the control and indicating equipment).

Furthermore it is checked if information on the triggering of the detector that are not deleted may be incorporated in the Zwangsläufigkeit of the IAS or, alternatively, are deleted automatically with the setting.

Pass/fail criteria: The test is passed if a respective display is existing and this display may be set and reset accordingly.

12.8 Function test

12.8.1 Function test by the installer

It is checked if the function of the motion detector is testable for the installer and the maintenance service and if with the testing function the real performance features of the detector (e. g. sensitivity, detection range) are identifiable.

Pass/fail criteria: The test is passed if a respective display is existing and this display may be set and reset accordingly.

12.8.2 Function test by the operator

It is checked if the function of the motion detector is testable in an easy manner for the operator (walk test function), the function display is unambiguous and is or may be effected in the vicinity of the detector.

Note: The design of the display is tested according to clause 14.1.2.

Furthermore it is checked for detectors of class B and C, if the displays of the test function may be switched on/off by the operator (e. g. at the control and indicating equipment or a special operating device).

Pass/fail criteria: The test is passed if a respective display is existing and this display may be set and reset accordingly.

12.9 Tamper

12.9.1 Tamper protection

12.9.1.1 Design

By visual and function check it is ascertained if the housing of the motion detector is sufficient stable for its purpose and if existing covers are affixed in a mechanically stable manner and if the inside of the detector is not visible during intended operation.

For motion detectors of class A, B and C it is checked if

- Display and operating devices are designed such that they do not weaken the stability of the housing and do not allow reach-in in the device
- Fixing screws of assembly parts are not visible once being installed properly
- The opening of the detector is possible only with suitable tools

For this purpose the test engineer tries – without use of suitable tools – manually to gain access to the inside of a detector which is mounted at a wall without hold up at the wall.

Pass/fail criteria: The test is passed if it is not possible to gain access to the inside of the detector.

12.9.1.2 Tearing and re-orientation

For motion detectors of class B and C it is checked, if persons that are not authorised may change the detection range of the motion detector with simple physical force by re-orientation or tearing off. For this purpose, by using simple physical force it is torn at the detector (without hold up at the wall) respectively it is tried with both hands to re-orient the detector. The detector shall be released of the mounting surface (wall) neither partly nor in complete at this trial; when re-orientation attempting it shall not be possible to change the adjustment direction (direction of view).

Pass/fail criteria: The test is passed if neither part nor complete release of the mounting surface is possible by this conditioning nor the adjustment direction is changeable.

12.9.2 Tamper monitoring

12.9.2.1 Detection of opening of a motion detector

For detectors of class B and C a visual check is made to ascertain if

- The opening of the detector is detected and signalled if this causes access to security relevant functions
 - The inside of the detector and the opening monitoring are protected against access as long as the monitoring has responded
 - As cover contacts only snap switches according to DIN 41636 or equivalent equipment is used
 - The contact areas of the switches are of golden material or equivalent
- Note: Alternatively, protective gas contacts may be used if they cannot be influenced from the outside.*
- The minimum response duration (dwell time) of the opening monitoring is indicated by the manufacturer in the technical documentation if the motion detector disposes of a conventional interface.

Pass/fail criteria: The test is passed if the detector generates a tamper signal or a tamper message before access to the inside of the detector is gained.

12.9.2.2 Detection of masking

For motion detectors of class C it is checked if in the unset state of the IAS a significant reduction of the intended function is impeded. If a reduction of function may not be impeded, an alarm shall be signalled.

The specimen is mounted and wired according to the manufacturers instructions and connected to a supply and processing unit. After adjustment of detection range, sensitivity etc. to minimal values the detection function and detection range of the specimen are tested.

In a first trial the following masking materials are held in front of the detector in a distance of 40 cm:

- White and black cotton drapery
- White and black soft wool drapery
- White and black writing paper (matt)
- 1 mm thick steel plate
- 2 mm thick aluminium plate
- 1 mm thick white and black cardboard
- Polystyrene
- White foamed polystyrene plate
- White and black plastics
- Glass
- 3 mm thick transparent bright acrylic plate
- Transparent plastic film

The dimensions of all materials is DIN A4. The distance between masking material and detector is then reduced in steps of 5 cm until the masking test is detected respectively signalled within 30 s and in a distance of at least 10 cm for all materials.

In a second test the following masking materials are used:

- Plastic mass applied directly on the detector
- Transparent self adhesive foil applied directly on the detector
- Hair spray applied directly on the detector
- Clear gloss lacquer applied directly on the detector
- Spray bandage applied directly on the detector

The reduction of range by more than 50 % as well as the fading-out of complete levels or zones in the detection range for infrared motion detectors shall be detected and signalled. Each 30 s after masking or after curing of the sprays/lacquers the detection function and the range of the specimen are tested.

Pass/fail criteria: The test is passed if the detector generates masking signals or messages within the required time and is operating in intended manner despite the masking.

Furthermore it is checked if the detector does not adapt to the masked condition and signals operationability, e. g. by longer masking times (0,5; 1; 2 h).

Pass/fail criteria: The test is passed if the detector still generates masking signals or messages.

The masking is then removed (as far as possible) and it is checked if the masking process has not negatively influenced the function of the detector. For this purpose a test of the basic function is performed respectively.

Pass/fail criteria: After removal of the masking materials the detector shall still operate as intended.

Note 1: When using plastic mass and lacquers a renewed test shall be performed after drying of the materials – if appropriate. Depending on the construction of the detector repeated attempts with different adjustments may become necessary.

Note 2: If single masking attempts lead to a significant influence and other attempts do not so, this shall be recorded in the test report with indication on frequency, reproducibility and severity.

Note 3: Should in praxis further masking attempts are known, additional tests may become necessary.

12.9.2.3 Detection of removal of the mounting surface

For wireless detectors of class B and C as well as for wired detectors of class C the function of the back tamper device by removal of the detector from its mounting surface is tested. The detector is again mounted at the mounting surface without the fixing screws, unless they form a part of the tamper detection device. The detector is slowly prised from the mounting surface and it is tried to prevent the tamper device from triggering by inserting a strip of steel with dimensions 100 mm and 200 mm long, 10 mm to 20 mm wide and 1 mm thick, between the rear of the detector and its mounting surface.

Pass/fail criteria: The test is passed if a tamper signal or a tamper message has been generated before the tamper device or a detectors function have been set out of operation.

12.9.3 Immunity against magnetic influences

Test 1

For motion detectors of classes B and C a test according to VdS 2110 is performed. Before and after conditioning a test of the basic functions (basic detection test) is performed. During conditioning no change of state shall occur (e. g. no signal) and/or blockade of the function (e. g. relay).

Pass/fail criteria: The test is passed if the conditioning does not prevent correct generating of signals and messages.

Test 2

Motion detectors of classes B and C are connected to the power supply and a duration of 120 s is passed. By placing in sequence a single pole of a magnet of type 1 and type 2 according to annex A on each surface of the detector housing it is tried to prevent intrusion, tamper and fault signals or messages. During each conditioning a basic detection test is performed and the correct generating of intrusion, tamper and fault signals or messages is tested. The tests are repeated with the respective other pole.

Pass/fail criteria: The test is passed if the conditioning does not prevent the correct generating of signals and messages.

12.9.4 Significant reduction of range (option)

At a distance of 55 % of the detection range as indicated by the manufacturer a test point is determined at the axis of the detector. Across and in parallel to the axis and in a distance of 45 % of the detection range as indicated by the manufacturer an obstacle is placed which blocks the respective physical parameters as corresponding with the detectors technology. As an example, for the test of passive infrared detectors the obstacle shall block the infrared radiation respectively for the test of a dual detector with passive infrared and microwave technology the blocking shall concern both infrared and microwave technology.

The obstacle has on each side of the detectors axis a horizontal distance of $\pm 2,5$ m and a vertical height of 3 m, as shown in figure 12.12.

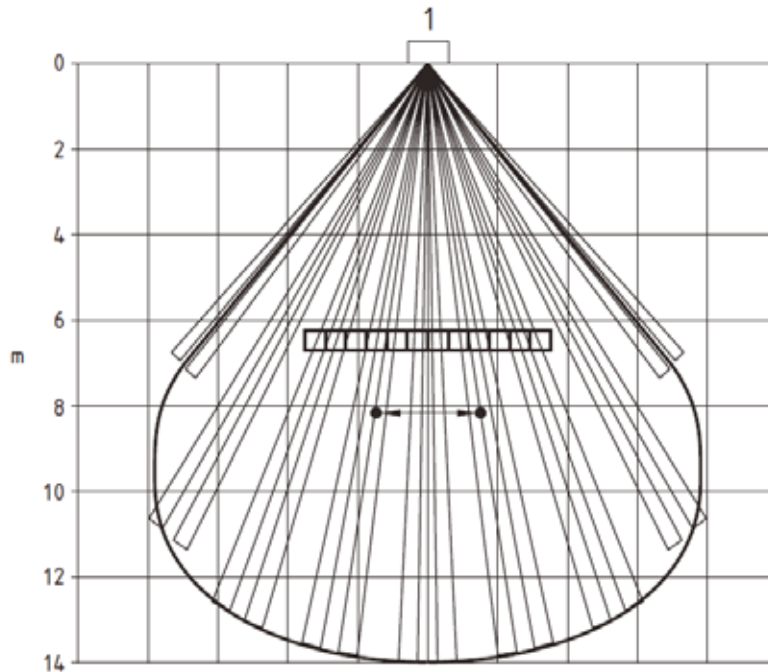

Figure 12.12: Test of a significant reduction of range

The test person (standard walk test target) shall move from the start to the end on one way. At the end of the walk test the test person (standard walk test target) shall stop for at least 20 s before another walk test is performed.

Pass/fail criteria: If an obstacle is present, a masking signal or a fault message shall be generated.

13 Test on functional reliability

13.1 Function monitoring

13.1.1 Self test (internal)

For motion detectors of class C it is checked if the failure or a fault of programmable processing units (failure of microprocessor, hang-up of a program, faults of security relevant storage device) are detected and available as message.

Note: For complex functions it may become necessary to require further information for the test at the manufacturer.

Furthermore it is checked if security relevant functions (e. g. signal processing and evaluation) of the motion detectors are automatically monitored as far as possible and if detected faults are signalled (e. g. as fault message). Alternatively it is checked if it is ensured by another method that the failure of a motion detector does not reduce the functional reliability of the IAS (e. g. redundant detector).

The basic detection test is performed in order to verify if the detector is operational.

Pass/fail criteria: This part of testing is passed if the detector generates an intrusion signal or an intrusion message.

The detector is to be monitored during local self test.

Pass/fail criteria: The test is passed if the detector does not generate intrusion, tamper, fault signals or messages.

The signal output of the sensor is shortened to ground or a respective measurement is taken according to the manufacturers recommendations.

The detector is to be monitored during self test. For detectors which dispose of more than one sensor signal output the tests shall be repeated for each output. Following these tests the detector shall generate a fault signal or a fault message and shall neither generate intrusion signals or messages nor tamper signals or messages.

Pass/fail criteria: The test is passed if an internal self test leads to a fault signal/message when a respective fault has been simulated.

13.1.2 Remote self test (option for grade 4 according to EN 50131-2-x)

Detectors of grade 4 shall be monitored on reaction during remote self tests. The detector shall generate an intrusion signal or intrusion message and shall not generate tamper or fault signals or messages.

The signal output of the sensor is shortened to ground or a respective measurement is taken according to the manufacturers recommendations. Detectors of grade 4 shall be monitored on reaction during remote self tests. For detectors which dispose of more than one sensor signal output the tests shall be repeated for each signal output. The detector shall generate a fault signal or a fault message and shall neither generate intrusion signal or intrusion message nor tamper signal or tamper message.

Pass/fail criteria: The test is passed if an internal self test leads to a fault signal/message when a respective fault has been simulated.

13.2 Functional reliability during operation

13.2.1 Operating voltage

This test is not applicable on detectors with power supply type C according to DIN EN 50131-6, power supplies (e. g. battery).

It is checked if the manufacturer has specified in his technical documentation the operating voltage and the range of operating voltage (at least nominal voltage $U_N \pm 25\%$). Furthermore the values within this specification are tested as follows for secure function:

- Following the test on operating voltage range with a test B1b according to table 6.02 before and after conditioning a test on the basic functions according to clause 11.2 of these guidelines is performed. During conditioning no change of state (e. g. no signal) shall occur.

Pass/fail criteria: This part of the test is passed if the detector does not generate unintended signals or messages during the test.

- Following the test on operating voltage step change system voltage (B2b) with a test B2b according to table 6.02 before and after conditioning a test on the basic function according to clause 11.2 of these guidelines is performed. During conditioning no change of state (e. g. no signal) shall occur.

Pass/fail criteria: This part of the test is passed if the detector does not generate unintended signals or messages during the test.

- The detector is connected to a square wave generator which is limited to a maximum current of 1 A and capable of switching from the nominal supply voltage V to the

nominal voltage $V \pm 25\%$ in 1 ms. The input voltage is set to nominal voltage V and the detector is allowed to stabilise for at least 180 s. Intrusion and fault signals or messages are monitored on reaction. Then ten successive square wave pulses from nominal supply voltage V to $V + 25\%$ are applied for a duration 5 s at intervals of 10 s. The test on voltage step change is repeated for the voltage range V to $V - 25\%$.

Pass/fail criteria: This part of the test is passed if the detector does not generate unintended signals or messages during the test.

13.2.2 Operating voltage ripple

This test is not applicable for detectors with power supplies of type C according to DIN EN 50131-6.

The detector is operated with an operating voltage of 12,0 V (24,0 V). The operating voltage is superimposed by a sinusoidal voltage (frequency = 100 Hz) with an amplitude of 1,0 V_{ss} (2,0 V_{ss}). For other operating voltages the indications of the manufacturer are decisive.

During conditioning no change of state shall occur (e. g. no signal). Furthermore the detection features of the motion detector shall be maintained also in case of existence of a superimposed sinusoidal voltage (test of basic functions according to clause 11.2).

After conditioning a test on the basic functions according to clause 11.2 of these guidelines is performed.

Pass/fail criteria: This part of the test is passed if the detector generates an intrusion signal or an intrusion message.

13.2.3 Slow input voltage change and input voltage range limits

This test is not applicable to detectors with power supplies of type C according to DIN EN 50131-6, power supplies.

The detector is connected to a suitable variable, stabilised power supply.

The supply voltage is raised from zero at a rate of $0,1 \text{ Vs}^{-1}$ in steps not greater than 10 mV until the nominal supply voltage $V - 25\%$ is reached, or the minimum supply voltage specified by the manufacturer, whichever is lower. The detector is allowed to stabilise for 180 s.

Intrusion and fault signals or messages are monitored on reaction and the basic detection test is performed.

Pass/fail criteria: This part of the test is passed if the detector generates an intrusion signal or an intrusion message.

The input voltage is reset to the nominal $V + 25\%$ or the maximum level specified by the manufacturer, whichever is greater. The detector is allowed to stabilise for 180 s. Intrusion and fault signals or messages are monitored on reaction and the basic detection test is performed.

Pass/fail criteria: The basic detection test shall lead to an intrusion signal or an intrusion message and shall not lead to fault signals or fault messages.

The supply voltage of detectors of class C is lowered at a rate of $0,1 \text{ Vs}^{-1}$ in steps of not more than 10 mV until a fault signal or a fault message is generated. The basic detection test is performed.

Pass/fail criteria: Detectors of class C shall generate a fault signal or a fault message prior to the situation where no intrusion signal or intrusion message is generated when the basic detection test is performed.

13.2.4 State beyond the operating voltage range

This test is not applicable to detectors with power supply of type C according to DIN EN 50131-6, power supplies.

The operating voltage of detectors of class B and C is lowered until it has fallen below the voltage range as specified by the manufacturer and the specified performance features (e. g. detection range, sensitivity) are no more available.

Pass/fail criteria: The test regarding low voltage is passed if the detector generates a fault signal or message and and – if intended as option – an additional intrusion signal or an intrusion message is triggered.

The test regarding total loss of power is passed if the detector generates an intrusion signal or message and and – if intended as option – an additional fault signal or an fault message is triggered.

Alternatively, for BUS-based systems, the total failure of the power supply may be determined by the failure of data communication with the detector.

13.2.5 Renewed disposition for signalling

Test 1

The test person (standard walk test target) moves from a position being directly in front of the detector in a distance of approx. 50 % of the adjusted detection range (see figure 13.01 and figure 13.02) with a velocity of 1 m/s and in an angle of 45° to the line joining the starting point SWT and the detector in direction towards the detector.

After signalling the test person turns by 180 ° and stops for 10 s; the covered distance is recorded. Then the test person walks back with a velocity of 1 m/s in direction to its starting point; in case of a signal, the test person immediately stops. Also here the covered distance is recorded.

Pass/fail criteria: The test is passed if the value of the last distance made is differing at maximum by 30 % of the value of the distance made at the first walk test.

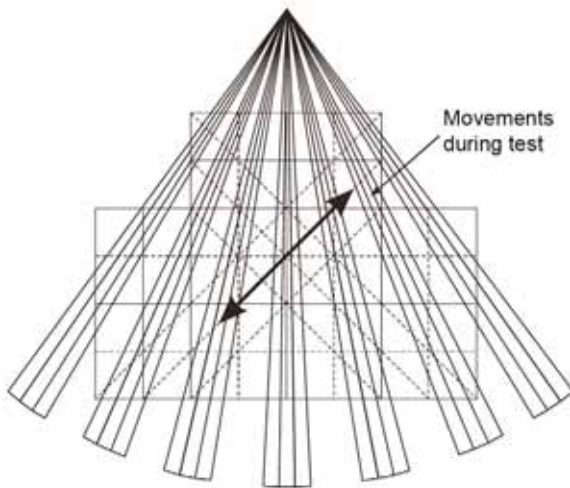

Figure 13.01: Test of renewed disposition for signalling of infrared motion detectors

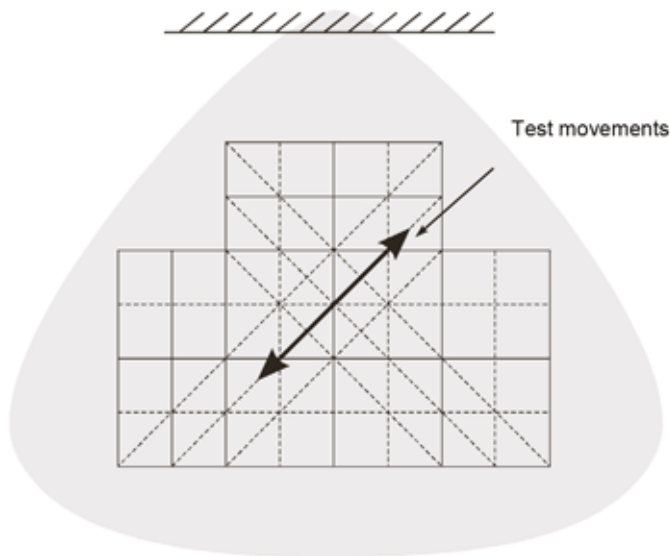

Figure 13.02: Test of renewed disposition for ultrasonic and microwave detectors

Test 2

The detector is set in operational status with an active display. It is allowed to stabilise for 180 s. The basic detection test is performed, the response behaviour is recorded.

After defined duration between intrusion signals and messages the basic detection test is performed once more. The response behaviour is newly recorded.

The intrusion signal is deactivated. After defined duration between the signals again the basic detection test is performed and the response behaviour is recorded.

Pass/fail criteria: The test is passed if the detector generates an intrusion signal or an intrusion message as reaction to the basic detection test. For the first and second basic detection test the intrusion signal or the intrusion message and the intrusion detection signal shall react at the same time. For the third basic detection test not indication shall be effected.

13.2.6 Operationability after connecting to the operating voltage

It is checked if the manufacturer has indicated in his technical documentation in which way the motion detector securely functions after being connected to the operating voltage.

Then it is checked if the motion detector securely functions in the time as indicated by the manufacturer or at least 120 s after it has been connected to the operating voltage. For this purpose the nominal voltage (e. g. 12 V=) is applied and after 120 s a test on the basic functions is performed.

Pass/fail criteria: This part of the test is passed if the detector generates an intrusion signal or an intrusion message.

13.3 Constructional requirements

13.3.1 Reliability of assembly elements

It is checked if the assembly elements regarding their performance features are correctly dimensioned. The temperatures of the assembly elements are calculated during the climatic tests. For this purpose a check of the technical data of the manufacturer is performed.

Pass/fail criteria: The test is passed if it is proven that the relevant elements are chosen according to their intended purpose and the respective environmental class.

14 Test of operational reliability and operation

14.1 Constructional requirements

14.1.1 Fixing and adjustment

A visual check and a test of function is performed in order to determine if the motion detector is designed such that installation and – if appropriate – adjustments are possible in a practice-orientated manner. In case of use of special tools it is checked if the respective tools are made available by the manufacturer of the motion detector (e.g. for techniques of cutting/clamping). Furthermore it is checked if the manufacturer made available respective adjustment aids.

Pass/fail criteria: This requirement is fulfilled if practice-orientated installation is possible and the information, adjustment aids and tools are made available.

14.1.2 Displays

It is checked if available displays of operational statuses of detectors (e. g. fault) are visible for the operator of the IAS at an ambient luminance intensity of 5 lux up to 500 lux in a distance of 3 m within an angle of 22,5 ° which is measured on a line through the centre of the active optical display in vertical to the mounting surface.

Furthermore it is checked if available audible displays dispose of a minimum noise level of 60 dB(A) – measured according to DIN 45631 – in a distance of 1 m from the detector.

Pass/fail criteria: This requirement is fulfilled if displays are visible and unambiguous (confusion not possible) and correspond with the required criteria.

14.1.3 Degree of protection

Before conditioning a test on the basic function according to clause 11.2 of these guidelines is performed.

The test on degree of protection (IP 3x) may be performed by a visual check. In case of doubt the test as follows is performed: A straight, inflexible steel wire or bar with a diameter of (2,5 +0,05/-0) mm is applied with a force of (30 ± 3) N on random points against the specimen (against the housing).

Pass/fail criteria: The test is passed if it is neither possible to penetrate into the detector with the steel wire or bar nor interfere security relevant function with.

14.1.4 Sealability

It is checked if motion detectors of **class B and C** after intended installation are sealable and if the sealing is sufficiently secure (e. g. by attempts to remove the seal without destruction).

Pass/fail criteria: The test is passed if an opening of the detector is not possible without visible traces at the seal and the seal cannot be removed or replaced without visible damage.

14.1.5 Parameterisation

It is checked if the device for parameterisation of the motion detector is designed such that the parameterisation is possible only by the installer and only with the agreement of the operator (“down-loading”).

Note: This test shall be performed – if appropriate – with other system components of the IAS (e. g. control and indicating equipment).

Note: Not applicable if a maintenance is inefficient and therefore a substitution is made.

Pass/fail criteria: The test is passed if the parameterisation is possible only e. g. by a download-function with the agreement of the operator.

14.1.6 Freedom of potential, isolation resistance

It is checked with a measurement equipment for resistance (measurement voltage 30 V at maximum) if the motion detector is designed free of potential to its mounting surface and if the isolation resistance is 500 kΩ at least. The test time is 60 s.

Pass/fail criteria: The test is passed if the freedom of potential of the detector is possible by parameterisation e. g. with a download-function only with the agreement of the operator.

14.1.7 Shielded lines

It is checked if the motion detector is designed such that when using shielded line the shields may be connected with each other in a reliable manner.

Pass/fail criteria: The test is passed if the shield may be reliably connected when using shielded lines.

14.1.8 Strain relief

Is a relief of strains for connecting elements of cables and wires necessary, this is tested by pulling at the cables and wires for 10 s with a force of 50 N.

Pass/fail criteria: The test is passed if the forces are not transferred to the connection contacts (visual check).

14.2 Provision of functions

14.2.1 Technical data

It is checked if technical data is available in German language and if these documents contain all parameters which are necessary for a reliable operation of the system component.

Pass/fail criteria: The test is passed if the necessary documentation and information is available in understandable manner.

14.2.2 Mounting and installation instruction

It is checked if mounting and installation instructions are available and if these documents are adequate for the mounting and installation.

Furthermore it is checked if the required documentation is available and if the mounting and installation instruction contains the necessary indications on adjustment and maintenance of the system component and describe the limits of application of the system component (including indication on classes as well as for which sites of installation the motion detector is suitable) and if adjustments that are not admitted (e. g. minimal sensitivity, minimal detection range) are clearly identified at the detector or in the technical documentation.

Furthermore it is checked if – where appropriate – a note is available that detectors which dispose of a large detection range shall not be used in small rooms.

Pass/fail criteria: The test is passed if the necessary documents and information is available in understandable manner.

14.3 Operation

If an operation of the motion detector by the operator of the IAS is necessary or shall be possible, an evaluation is effected in order to determine if a simple operation of the motion detector is possible and if available displays are clear and understandable.

Pass/fail criteria: The test is passed if the necessary documentation and information is available in understandable manner.

14.3.1 Operating instructions

It is checked if an operating instruction according to the requirements is available and if this instruction describes in a clear and understandable manner the operation of the motion detector to the operator.

If appropriate, several persons shall try to operate the detector only on base of the operating instruction.

Pass/fail criteria: The test is passed if the necessary documentation and information is available in understandable manner.

14.3.2 Adjustment elements

A visual check and a function check is performed in order to verify if the manufacturer has indicated the detection features of the detector for all extreme values of the adjustment elements.

If several adjustment elements exist, the functions and effects of these elements shall be described in the technical documentation.

Pass/fail criteria: The test is passed if the necessary information is available in understandable manner.

For detectors which dispose of an electrical adjustment element (e. g. detection range) only, it is checked if no adjustment "nil" is possible by this element (i. e. no function).

Furthermore it is checked by practical attempts if effected adjustment are traceable such that a deviation of at maximum 20 % occurs (Example: Adjustment on 5 m and verification of this detection range – recording of adjustment – change of adjustment – adjustment to recorded value – check of detection range). The test is made for three adjustment values at least (e. g. low, medium and large detection range).

Pass/fail criteria: The test is passed if the necessary information is available in understandable manner.

15 Test of the interfaces to the IAS/HAS

Note: Depending on the design of the single system components a joint test may become necessary.

15.1 Interface for conventional line technology

The following tests are performed for IAS with a remote supply of the motion detectors and a conventional line technology (terminal resistance).

15.1.1 Inputs

15.1.1.1 Operating voltage

It is checked if the motion detector disposes of connecting elements for the supply voltage.

Pass/fail criteria: The test is passed if the respective connecting elements are available.

15.1.1.2 Switching on/off of the function display

For motion detectors of class B and C it is checked if an input for the function test of the detector which is performed by the operator for switching on/off of the function display is available and if the function and parameters of the input correspond with the requirements.

Pass/fail criteria: The test is passed if a respective input is available.

Note: If detectors of class A have this input they shall correspond with the same requirements and is tested accordingly.

15.1.1.3 Operation modes

If motion detectors dispose of inputs for switching on/off of possibly available operation modes, it is checked if the functions and parameters of the inputs correspond with the requirements.

Pass/fail criteria: The test is passed if the required parameters or those as prescribed by the manufacturer for the different operation modes are kept.

15.1.1.4 Additional inputs

It is checked if respective parameters are indicated by the manufacturer and these correspond with the parameters of the detectors.

Pass/fail criteria: The test is passed if the required parameters or those as indicated by the manufacturer are kept.

15.1.2 Outputs

15.1.2.1 Interface for intrusion messages

The following tests are performed:

- It is checked if the output is designed potential free ($\geq 10 \text{ M}\Omega$) with a resistance measurement meter (measurement voltage 30 V at maximum)
- It is checked if the capacity of the output is at least 50 mA at 30 V=. As confirmation a data sheet is sufficient.
- It is checked if the resistance in series with the output does not exceed $47 \text{ }\Omega$ (output idle state, low resistive) with a resistance measurement meter (measurement voltage 30 V at maximum).
- It is checked if the output is closed in idle state (low resistive) and opens in case of message (highly resistive).
- It is checked if the response duration lies between $\geq 1 \text{ s}$ to $\leq 10 \text{ s}$.
- It is checked if the output is closed again/again low resistive 10 s at the latest after end of the criteria that triggered the message.
- It is checked if a connection facility for a monitoring element is available (e. g. final resistance).

Pass/fail criteria: The test is passed if the required parameters or those indicated by the manufacturer are kept and the respective connection facility is available.

15.1.2.2 Additional electrical output for intrusion messages

Note: This output is an option with requirements.

It is checked if an additional electrical output corresponds with the requirements regarding the function and the parameters and if the respective values are indicated by the manufacturer.

Pass/fail criteria: The test is passed if the required parameters or those indicated by the manufacturer are kept.

15.1.2.3 Interface for tamper messages

For motion detectors of class B and C the following tests are performed:

- It is checked if the output is designed potential free ($\geq 10 \text{ M}\Omega$) with a resistance measurement meter (measurement voltage 30 V at maximum)
- It is checked if the capacity of the output is at least 50 mA at 30 V=. As confirmation a data sheet is sufficient.
- It is checked if the resistance in series with the output does not exceed $47 \text{ }\Omega$ (output idle state, low resistive) with a resistance measurement meter (measurement voltage 30 V at maximum).
- It is checked if the output is closed in idle state (low resistive) and opens in case of message (highly resistive).
- It is checked if the response duration corresponds with the response of the tamper detector.

Pass/fail criteria: The test is passed if the required parameters and those indicated by the manufacturer are kept.

15.1.2.4 Interface for messages of the function monitoring

For motion detectors of class C the following tests are performed:

Note: If detectors of class A and B dispose of this output it shall similarly correspond with the requirements and is tested accordingly.

- It is checked if the function and the values of the output correspond with the indications of the manufacturer.
- It is checked if the output is actuated for at least 1s and for the duration of the fault.

Pass/fail criteria: The test is passed if the required parameters and those indicated by the manufacturer are kept.

15.1.2.5 Additional outputs

It is checked if the respective values are indicated by the manufacturer and correspond with the parameters of the detector.

Pass/fail criteria: The test is passed if the parameters indicated by the manufacturer are kept.

15.2 Test of the interface for other techniques

A visual check is made to ascertain if the features of the interface specified by the manufacturer.

Furthermore, in connection with the associated system techniques (e. g. interface assemblies in an intrusion ancillary control equipment) if the inputs and outputs are working as intended.

Pass/fail criteria: The test is passed if the inputs and outputs are working as intended.

16 Protection against environmental influences

16.1 Limits of application

Motion detectors shall not be negatively influenced in their function by environmental influences. Depending on the functional principle applied the environmental influences may have various effects on the operational behaviour. The limits of application (e. g. climates) shall therefore be specified by the manufacturer. The requirements and test methods of the Guidelines for Intruder Alarm Systems, Protection against Environmental Influences (VdS 2110) are to be applied accordingly.

Pass/fail criteria: During testing no unintended signals or messages shall be effected. After testing no signs of physical damage shall exist and the detector shall furthermore fulfil the requirements of the basic detection test.

16.2 Climates (sun radiation)

For new detectors the absorption value of the sensor covers is measured with suitable measures (e. g. by measuring the infrared transparency of the sensor cover or of the drum lens of infrared motion detectors). Then the detector resp. the critical material is subjected to normal sun radiation over a period of 12 months behind a normal glazing (window) at the south front of a building. At least one reference sample is deposited for the same period in complete darkness.

In intervals of 3 months it is measured if the features of the detector (detection range, sensitivity) are changing. This may be performed e. g. by measuring the infrared transparency of foil/reflector material.

Pass/fail criteria: The test is passed if the features have not changed by more than 10 % within one year.

Annex A (normative) – dimensions and requirements of standardised test magnets

Requirements and normative references

The following standards form the base for the selection of the test magnets:

IEC 60404-8-1, Magnetic materials – Part 8-1: Specifications for individual materials – Magnetically hard materials

IEC 60404-5, Magnetic materials – Part 5: Methods of measurement of magnetic properties

IEC 60404-14, Magnetic materials – Part 14: Methods of measurement of the magnetic dipole moment of a ferromagnetic material specimen by the withdrawal or rotation method.

The field strength of the magnet is determined by the magnetic materials, by remanence (B_r) in mT, the product of energy $(BH)_{\max}$ in kJm^{-3} and the polarisation of the working point in mT.

The relevant values, dimensions and measurement points for the test magnets can be found in the following drawings and tables. For calculations, measurements and calibrating the test magnets refer to the above standards.

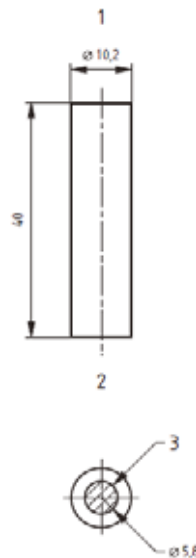

1 north pole

2 south pole

3 north pole (shaded)

Material	AlNiCo 34/5 (Code number R1-1-10)
Remanence B_r , min	1.120 mT
Product of energy $(BH)_{\max}$	34 kJm^{-3}
Polarisation of working point	0,835 T \pm 2 %

Figure A.1: Test magnet type 1

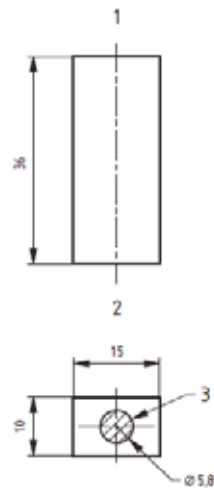

1 north pole

2 south pole

3 north pole (shaded)

Material

NdFeB N38 (REFeB 280/120 –
Codenummer R5-1-7) - nickel

Remanence B_r , min

1.240 mT

Product of energy $(BH)_{\max}$

280 kJ/m³

Polarisation of working point

Remanence B_r – 5 %

Figure A.2: Test magnet type 2

Annex B (normative) – Test matrix

The individual tests are performed in sequence as determined in the following test matrix. If a specimen fails during the tests, it shall be decided in single cases – if appropriate with the agreement of the manufacturer – if and with which test step the testing is continued.

Note: The sequence in the test matrix is not identical with the order of clauses in these guidelines.

Test n°	Test	Clause of these guidelines	With basic detection test according to clause 10.5	specimen
1	Completeness	11.1	none	All
2	Basic functions	11.2	none	All
3	Adjustment values	11.3	none	All
4	Initial running	11.4	none	All
5	General tests	11.5	none	All
9	Technical data	14.2.1	none	All
10	Mounting and installation instructions	14.2.2	none	All
11	Detection performance: walking without interruption	12.3	none	1
12	Detection performance: walking with intermittent movement	12.4	none	1
13	Immunity against unwanted alarms	12.5	none	1
14	Overriding by bypassing the monitoring method	12.6	none	1
15	Triggering identification	12.7	none	1
16	Function test	12.8	none	
17	Tamper	12.9	none	1
18	Tamper monitoring	12.10	none	1
20	Function monitoring	13.1	none	1
21	Functional reliability during operation	13.2	none	1
22	Functional reliability: constructional requirements	13.3	none	1
23	Operational reliability: constructional requirements	14.1	none	1
24	Provision of function	14.2	none	1
25	Operation	14.3	none	1
26	Interface for conventional line technology	9.4	none	1

Test n°	Test	Clause of these guidelines	With basic detection test according to clause 10.5	specimen
27	Limits of application	See in the following according to VdS 2110		
28	Climates (sun radiation)	16.2	x	2
43	Dry heat (T1)	16.1	x	3
44	Dry heat (T2)	16.1	x	3
45	Cold (T3)	16.1	x	3
46	Damp heat, steady state (T4)	16.1	x	4
47	Damp heat, steady state (T5)	16.1	x	4
48	Damp heat, cyclic (T6)	16.1	x	4
49	Damp heat, cyclic (T7)	16.1	x	4
50	Protection against debris and water	16.1	x	5
51	Protection against corrosion	16.1	x	9
52	Shock (M1)	16.1	x	6
53	Impact (M1a)	16.1	x	6
54	Impact (M2)	16.1	x	6
55	Vibration, sinusoidal (M3)	16.1	x	7
56	Vibration, sinusoidal (M4)	16.1	x	7
57	Electrostatic discharge of low energy lower	16.1	x	8
58	Radiated radio-frequency electromagnetic fields	16.1	x	8
59	Conducted radio-frequency (E2b)	16.1	x	8
60	Conducted electrical fast transient - burst	16.1	x	8
61	Conducted surge (4a)	16.1	x	8

Annex C – Procedure for the calculation of the average temperature difference

C.1 Measurement and calculation of the real average temperature difference between the SWT and the background

The calculation of real average temperature difference D_t , of the selected SWT requires non-contact temperature measurement of the body and of the immediately adjacent background and averaging of the differences between these. The thermometer shall have a wavelength sensitivity range of 6 m to 18 μm , a collection angle no larger than 3°, and its emissivity setting shall be 95 %.

Five separate zones of the human form shall be measured for surface temperature, and the differences between the zone and the background weighted and summed to give D_t :

Body zone	Body-background Temperature difference:	Significance: weighting factor	
Head	D_{tr1}	W_1	2
Chest	D_{tr2}	W_2	4
Back of hand	D_{tr3}	W_3	4
Knee	D_{tr4}	W_4	2
Feet	D_{tr5}	W_5	1

$$D_{tr} = \frac{\sum_{k=1}^5 D_{trk} \times W_k}{\sum_{k=1}^5 W_k}$$

C.2 Adjustment of equivalent average temperature difference between the SWT and the background

The equivalent average temperature difference between the SWT temperature and the immediately adjacent background temperature shall not be less than 2,8° C (3,5° C – 20 %). If D_{tr} is greater than 4,2° C (3,5° C + 20 %) one or more attenuation filters shall be placed directly over the detector lens or window to reduce the radiation received by the detector to within 20 % of that which would result from a temperature difference of 3,5° C.

Alternatively if D_t is greater than 4,2° C (3,5° C + 20 %) the SWT may wear an extra layer or layers of close fitting clothing, or the general background temperature may be raised. If D_{tr} is less than 2,8° C (3,5° C – 20 %) the general background temperature will need to be lowered.

HDPE sheets may be used as filter material for SWT signal adjustment. The percentage reduction in radiation received by the detector obtainable with these materials is best established with a suitable infrared spectrograph.

Examples of material thickness are 100 μ , and 200 μ m, which may give the following approximate signal reductions.

Material thickness	Approximate reduction of signal
100 μ m	20 %
200 μ m	36 %

Annex D – Equipment for walk test velocity control

D.1 General

The SWT is required to move at a variety of velocities during walk tests as specified in Table 5.03. The required velocities range from 0,1 ms⁻¹ to 4,0 ms⁻¹ \pm 10 %. A means of controlling these velocities is desirable.

D.2 Moving light sources guiding system

This equipment consist of a series of light emitting diodes (LEDs) mounting along the floor in the direction that the controlled walk test subject is desired to follow. They are driven by a variable time switch so that they flash in sequence across the floor, producing an apparent movement, which can be followed by the SWT.

D.3 Metronome

The metronome give an audible timing sound that can be used, in conjunction with a marked distance scale on the floor to instruct the SWT to move from one mark to the next as each beat from the metronome sounds.