



Locking Cylinders with Individual Locking Function

Requirements and Test Methods

Part 2: Electronic Locking Cylinders

Publisher and publishing house: VdS Schadenverhütung GmbH

Amsterdamer Str. 172-174

50735 Köln, Germany

Phone: +49 221 77 66 0; Fax: +49 221 77 66 341

Copyright by VdS Schadenverhütung GmbH. All rights reserved.

VdS Guidelines for Physical Security Devices

Locking Cylinders with Individual Locking Function

Requirements and Test Methods

Part 2: Electronic Locking Cylinders

CONTENT

1	General	4
1.1	Scope.....	4
1.2	Validity	4
2	Normative references	4
3	Terms and definitions	6
4	Classification	7
5	Requirements	8
5.1	Manufacturers declaration	8
5.2	Mounting instructions.....	8
5.3	Instruction manual	9
5.4	Marking	9
5.5	Dimensions	9
5.6	Loss of the power supply.....	10
5.7	Durability.....	10
5.8	Protection against environmental influences.....	10
5.9	Resistance against intelligent attacks	12
5.10	Requirements on entering and processing of codes.....	12
5.11	Resistance against physical attacks.....	16
6	Tests	16
6.1	Preconditions	16
6.2	Initial tests	18
6.3	General tests	18
6.4	Resistance against intelligent attacks	20
6.5	Test of input device and processing unit	20
6.6	Resistance against physical attacks.....	21
6.7	Additional tests	22
	Changes	22
	Annex A – Declaration of the manufacturer (normative)	23

1 General

1.1 Scope

This part 2 of the Guidelines for Physical Security Devices, Locking Cylinder with Individual Locking Function, VdS 2156-2, contains minimum requirements for electronic locking cylinders and is valid together with VdS 2156 as well as DIN 18 252 and DIN 1303.

Electronic locking cylinders may be operated with a code carrier, with biometric features, with a number and/or letter combination, with transponders or other techniques. The input of codes may – depending on construction – be performed with or without physical contact between code medium and input device. The sole use of mnemonic codes (e.g. input on a key board), however, is not admitted.

If electronic locking cylinders are used in connection with the setting/unsetting of an intruder alarm system (IAS) or if a triggering of a hold-up signal/message shall be possible further guidelines (e.g. VdS 2119, Guidelines for Intruder Alarm Systems, Ancillary Control Equipment, VdS 2271 and VdS 2314, Guidelines for Intruder Alarm Systems, Hold-up Triggering Devices) are valid additionally.

For software-controlled components VdS 2203, Guidelines for Alarm Systems, Software Controlled Components, Requirements and Test Methods, are valid additionally.

1.2 Validity

These guidelines are valid from 2007, September 1st; they replace the guidelines VdS 2156-2 : 2005-08 (02).

Note: This is a translation of the German guidelines; if there are any discrepancies, the German version shall be binding.

2 Normative references

These guidelines contain dated and undated references to other publications. The normative references are cited at the appropriate places in the clauses, the publications are listed hereafter. For dated references, subsequent amendments to or revisions of any of these publications apply to these guidelines only when announced by a change of these guidelines. For undated references the latest edition of the publication referred will be applied.

- **DIN 18 252** : 2006-12 Schließzylinder für Türschlösser: Begriffe, Maße, Anforderungen, Kennzeichnung
(Locking cylinder for door locks, terms and conditions, measurements, requirements and labelling)
- **DIN EN 1303** : 2005-04 Baubeschläge, Schließzylinder für Schlösser; Anforderungen und Prüfverfahren
(Hardware, locking cylinder for locks requirements and test methods)

- **DIN EN ISO 6988**: 1997-03 Metallische und andere anorganische Überzüge; Prüfung mit Schwefeldioxid unter allgemeiner Feuchtigkeitskondensation (Metallic and other non organic coatings – Sulfur dioxide test with general condensation of moisture)
- **EN 61 000-4-2** Elektromagnetische Verträglichkeit (EMV) – Teil 4: Prüf- und Messverfahren – Hauptabschnitt 2: Störfestigkeit gegen die Entladung statischer Elektrizität – EMV-Grundnorm (Electromagnetic compatibility (EMC) – Testing and measurement techniques – Electrostatic discharge immunity test – Basic EMC publication)
- **EN 61 000-4-3** Elektromagnetische Verträglichkeit (EMV) – Teil 4: Prüf- und Messverfahren – Hauptabschnitt 3: Störfestigkeit gegen hochfrequente elektromagnetische Felder (Electromagnetic compatibility (EMC) – Testing and measurement techniques – Radiated, radio-frequency, electromagnetic field immunity test)
- **EN 61 000-4-4** : 1995 Elektromagnetische Verträglichkeit (EMV) – Teil 4: Prüf- und Messverfahren – Hauptabschnitt 4: Störfestigkeit gegen schnelle transiente elektrische Störgrößen/Burst (Electromagnetic compatibility (EMC) – Testing and measurement techniques – Electrical fast transient/burst immunity test)
- **EN 61 000-4-5** : 1995 Elektromagnetische Verträglichkeit (EMV) – Teil 4: Prüf- und Messverfahren – Hauptabschnitt 5: Störfestigkeit gegen Stoßspannungen (Electromagnetic compatibility (EMC) – Testing and measurement techniques – Surge immunity test)
- **EN 61 000-4-6** Elektromagnetische Verträglichkeit (EMV) – Teil 4: Prüf- und Messverfahren – Hauptabschnitt 6: Leitungsgeführte Störgrößen, induziert durch hochfrequente Felder (Electromagnetic compatibility (EMC) – Testing and measurement techniques – Immunity to conducted disturbances, induced by radio-frequency fields)
- **IEC 60 068-2-1** Grundlegende Umweltprüfungen; Teil 2: Prüfungen, Prüfgruppe A: Kälte (Environmental testing – Part 2: Tests; tests A: Cold)
- **IEC 60 068-2-2** Grundlegende Umweltprüfungen; Teil 2: Prüfungen, Prüfgruppe B: Trockene Wärme (Basic environmental testing procedures – Part 2: Tests; tests B: Dry heat)
- **IEC 60 068-2-3** Grundlegende Umweltprüfungen; Teil 2: Prüfungen, Prüfgruppe Ca: Feuchte Wärme (Konstantprüfung) (Basic environmental testing procedures Part 2: Tests, Test Ca: Damp heat, steady state)
- **IEC 60 068-2-6** Grundlegende Umweltprüfungen; Teil 2: Prüfungen, Prüfung Fc: Schwingen (sinusförmig) (Environmental testing – Part 2: Tests; test Fc: Vibration (sinusoidal))
- **IEC 60 068-2-27** Grundlegende Umweltprüfungen; Teil 2: Prüfungen, Prüfung Ea: Schock (Basic environmental testing procedures – Part 2: Tests; test Ea and guidance: Shock)
- **IEC 60 068-2-30** Grundsätzliche Umweltprüfungen; Prüfungen; Prüfung Db und Anleitung: Feuchte Wärme, zyklisch (12 + 12 Stunden-Zyklus) (Environmental testing - Part 2-30: Tests – Test Db: Damp heat, cyclic)

- **IEC 60 068-2-75** Umweltprüfungen – Teil 2: Prüfungen, Prüfung Eh: Hammer-Prüfungen
(Environmental testing – Part 2: Tests; test Eh: Hammer tests)
- **VdS 2110** Guidelines for Intruder Alarm Systems, Protection Against Environmental Influences, Requirements and Test Methods
- **VdS 2119** Guidelines for Intruder Alarm Systems; Ancillary Control Equipment (ACE), Requirements
- **VdS 2156** Guidelines for Physical Security Devices, Locking Cylinder with Individual Locking Function, Requirements and Test Methods
- **VdS 2203** Guidelines for Alarm Systems, Software-controlled Components, Requirements and Test Methods
- **VdS 2271** Guidelines for Hold-up Triggering Devices, Requirements
- **VdS 2314** Guidelines for Intruder Alarm Systems, Hold-up Triggering Devices s, Test Methods
- **VdS 2344** Procedures for Testing and the Approval of Equipment, Components and Systems Used in Fire Protection and Security Technology

3 Terms and definitions

For general terms and definitions refer to DIN 18 252 and DIN EN 1303, clause 3. In addition the following definitions apply:

Attack, intelligent: Attack aiming to overcoming a locking cylinder preferably without tools aided by technical know-how, if necessary on base of the technical information of the respective component.

Biometric: Automated identification of persons by means of their physical characteristics.

Blocking element: Element which is addressed by the processing unit of a locking cylinder and which blocks or releases the operation of the lock.

Code: Information (e.g. combination of numbers and/or letters) that are entered into an input device via adequate interface (e.g. keypad).

It is differentiated between the opening code and the authorisation code:

- An opening code shall be entered to operate the locking cylinder.
- An authorisation code shall be entered to change the opening code or to change the programming.

Code, biometric: Information resulting from the physical characteristics of persons (owner of the code).

Code, physical: Information stored by physical means (on a data medium, e.g. key, magnetic card).

Code, mnemonic: Information (numeric or alphabetically) stored in the user's memory.

Code carrier: Item (or person) serving by means of its physical features as memory for a code.

Individual locking function: The individual locking of a cylinder, which is not a part of a master key system.

Input device: Device which takes up the information fed into and transforms it if required (e.g. into electrical signals).

Electronic locking cylinder: Element of a locking system for operating a cylinder lock. Electronic locking cylinders basically are composed of

- Input device
- Processing unit
- Blocking element

Processing unit: Element of the cylinder evaluating access authorisation and switching the blocking element.

Locked: State of a door or a window at which the movable wing in the closed condition is being blocked by a fastener.

4 Classification

Electronic locking cylinders are classified in accordance to their performances into the following classes:

All **class A** locking cylinders beside the higher requirements of these guidelines meet the requirements regarding the security against unauthorized opening according to DIN 18 252, class 21, 31 or 71.

- **Class A**
basic burglary protection
- **Class AZ**
basic burglary protection *with pulling protection*

All **class B** locking cylinders beside the higher requirements of these guidelines meet the requirements regarding the security against unauthorized opening according to DIN 18 252, class 42 or 82.

- **Class B**
medium burglary protection
- **Class BZ**
medium burglary protection *with pulling protection*
- **Class B+**
medium burglary protection
with high resistance against attacks with picking tools.
These cylinders are suited for the use in ancillary control equipment of intruder alarm systems.
- **Class BZ+**
medium burglary protection *with pulling protection*
with high resistance against attacks with picking tools.
These cylinders are suited for the use in ancillary control equipment of intruder alarm systems.

An equivalent of **class C** locking cylinders regarding the security against unauthorized opening to DIN 18 252 is not given.

- **Class C**
high burglary protection
with high resistance against attacks with picking tools.
- **Class C+**
high burglary protection
with high resistance against attacks with picking tools.
These cylinders are suited for the use in ancillary control equipment of intruder alarm systems.
- **Class CZ**
high burglary protection *with pulling protection*
with high resistance against attacks with picking tools.
- **Class CZ+**
high burglary protection *with pulling protection*
with high resistance against attacks with picking tools.
These cylinders are suited for the use in ancillary control equipment of intruder alarm systems.

In the following unless otherwise mentioned the naming of a classification references to all performances within this classification. (Example: If “class B” is mentioned the classes “B, BZ, B+ as well as BZ+” are referred to.)

Note: If for electronic locking cylinders the class C respectively CZ is confirmed, however, not the class C+ respectively CZ+ (i.e. these products are not suited for the use in ancillary control equipments of IAS) this is founded by the design of the cylinders. In spite of their high security against burglary and their high resistance against picking it is not possible e.g. to mount double-knob-shaped cylinders in an ancillary control equipment. For the categorization in class C+ respectively CZ+ the type series shall contain a half cylinder.

5 Requirements

The requirements of DIN 18 252 and DIN EN 1303 are valid with the following deviations and/or additions.

5.1 Manufacturers declaration

The approval of locking cylinders requires a filled manufacturers declaration according to annex A of these guidelines. The declaration is part of the documentation which has to be checked.

5.2 Mounting instructions

In addition to DIN 18 252 each delivery of one or more locking cylinders shall be provided with pictorial installation and operating manuals, written in German language.

Note: If the products are intended for the non-German speaking market instructions in English language are adequate.

The mounting instructions shall contain a clear and detailed description of the installation process as well as all security measures and conditions of use (e.g. indication of attack side if only one side of the cylinder is provided with a protection against drilling).

Especially a hint shall be given, that the cylinder is to be protected with a burglar resistant door plate (with or without pulling protection) of the respective class as well as a hint on the projection of the cylinder which is at maximum 3 mm.

5.3 Instruction manual

An instruction manual shall be provided for the user in German language.

Note: If the products are intended for the non-German speaking market an instruction manual in English language is adequate.

The instruction shall contain in clear and comprehensive form all items which are important for the user. Especially the following hints shall be included:

Electronic locking cylinder with physical code carrier

- The key is to be kept securely so that only authorised persons may have access.
- In case of lost of a key the lock shall be substituted immediately or shall be converted by change of the coding onto a new locking or the coding of the lost key shall be disabled/deleted.

Electronic locking cylinder with code input

- For choosing the code no personal data (e.g. birthdays) or other data shall be used which would allow a conclusion to the code from the person of the code owner.
- Is the code kept in written form, this document shall be kept like a physical code carrier (see above).
- The electronic locking cylinder shall be operated **several times with the door open** after being converted to a new code.

5.4 Marking

Every locking cylinder shall be labeled permanently with the name/mark of the manufacturer or the holder of the approval and the type designation and the class. The type designation shall be identical with type designation used in the technical documents and the advertising material and shall only be used for the approved locking cylinders.

In case of a one-sided protection against mechanical attacks the attack side shall be marked permanently.

In the mounted state of the locking cylinder no references to the code, protective measures nor class shall be visible.

A marking at the locking cylinder or at the code medium shall not admit direct conclusions to the code.

A marking of the locking cylinder or the key concerning the VdS approval being visible in the mounted state of the cylinder is permitted.

Note: Requirements on VdS-marking are described in VdS 2344.

5.5 Dimensions

Deviating from DIN 18 252, clause 4, pins, trips/cams or other devices may be attached at the cylinder body in a way, that they support themselves at the door plate in case of a pulling attack.

5.6 Loss of the power supply

A loss of the power supply shall not lead to a deactivation of the blocking function nor to a release of the electronic locking cylinders (i.e. the system shall not open independently nor shall an opening be possible without the necessary authorisation).

5.7 Durability

In addition to DIN EN 1303, clause 4.3, locking cylinders equipped with a cam the lock shall resist the force acting upon the cam during the locking procedure. Therefore deviating from DIN EN 1303, clause 5.3, a test according to clause 6.3.6 of these guidelines shall be performed.

5.8 Protection against environmental influences

5.8.1 Application limits

Approved locking cylinders according to these guidelines are suited for the use in interior rooms or open-air if sheltered against influences of weather.

Typically the requirements are standardised for all classes. Exception: For locking cylinders suited for the use in ancillary control equipment (class B+, BZ+, C+ and CZ+) the requirements regarding corrosion protection shall be fulfilled.

5.8.2 Climates

Electronic locking cylinders of each class shall meet the requirements according to table 5.01 without being influenced negatively.

Test (and specifications of the processing)	Functional test	Endurance test	Abbreviated description of the impact
Dry heat (T1) as spec. in IEC 60068-2-2	x		+ 70 °C, 16 h
Cold (T3) as spec. in IEC 60068-2-1	x		-25 °C, 16 h
Damp heat, steady (T5) as spec. in IEC 60068-2-3		x	+40 °C, 21 d 93 % rel. air humidity
Damp heat, cyclic (T6) as spec. in IEC 60068-2-30	x		+55 °C, 2 cycles
Damp heat, cyclic (T7) as spec. in IEC 60068-2-30		x	+55 °C, 6 cycles
Table 5.01: Climates			

5.8.3 Protection against corrosion

Electronic locking cylinders shall meet the requirements according to table 5.02 without being influenced negatively.

An SO ₂ endurance test (K3) is carried out according to DIN EN ISO 6998	Abbreviated description of the impact	Required for the classes
	0,2 l SO ₂ 5 cycles	A, AZ B, BZ
	0,2 l SO ₂ 15 cycles	B+, BZ+ C, CZ, C+, CZ+

Table 5.02: Protection against corrosion

5.8.4 Mechanical influences

Electronic locking cylinders shall meet the requirements according to table 5.03 without being influenced negatively.

Test (and specifications of the processing)	Functional test	Endurance test	Abbreviated description of the impact
Shock (M1) as specified in IEC 60068-2-271 ¹⁾	x		$\hat{A}(\text{ms}^{-2}) = 1000 - (200 \times M)$ 6 x 3 shocks, duration each 6 ms
Impact (M2) as specified in IEC 60068-2-75	x		0.5 J, 3 impacts per point
Strong impacts ²⁾	x		100 g, impulses of 6 ms
Vibration sinus (M3) as spec. in IEC 60068-2-6	x		10-150 Hz, 0.5 g, 1 cycle
Vibration sinus (M4) as spec. in IEC 60068-2-6		x	10-150 Hz, 1.0 g, 20 cycles

\hat{A} = peak acceleration, M = mass of the test specimen in kilograms

1) Test may be dropped for certain components if particular application instructions are given in the specifications.

2) Test is only carried out for movable parts (e.g. doors) of installed components.

Table 5.03: Mechanical influences

5.8.5 Electromagnetic compatibility

Electronic locking cylinders shall meet the requirements according to table 5.04 without being influenced negatively.

A functional test (K3) is carried out according to DIN EN ISO 61000	Abbreviated description of the impact
Electrostatic discharge of low energy (E1b) acc. to EN 61000-4-2	Each 10 times pos. and neg. contact discharge 2, 4 and 6 kV resp. air discharge 2, 4 and 8 kV
Radiated high frequency (radio-frequency) (E2a) acc. to EN 61000-4-3	80 – 2000 MHz, 10 V/m as well as 415-466 and 890-960 MHz, 30 V/m Modulation: AM 80 % (modulated with 1 kHz Sinus) for at least 3 s and followed by 3 times switching on/off of the carrier with 1 Hz as well as 1 kHz
Conducted radio-frequency (E2b) acc. to EN 61000-4-6	150 kHz-100 MHz, 140 dB μ V Modulation: AM 80 % (modulated with 1 kHz sinus) for at least 3 s and followed by 3 times switching on/off of the carrier with 1 Hz and 1 kHz
Conducted electrical fast transient with low energy – burst – (E3a) acc. to EN 61000-4-4	Each for a period of 1 min pos. and neg. mains 0.5, 1 and 2 kV, other circuits 0.25, 0.5 and 1 kV
Conducted slow surge with high energy – (E4a) acc. to EN 61000-4-5 The test is omitted if the length of cables within one system will not exceed 3 m (e. g. battery supplied electronic lock).	Mains 20 times pos. and neg. cl. 4: diff. 0.5; 1; 2 kV. Other circuits 5 times pos. and neg. cl. 3: line-to-line 0.5; 1 kV and line-to-ground 0.5, 1, 2 kV
Static magnetic fields (E6)	150 mT
Table 5.04: Electromagnetic compatibility (EMC)	

5.9 Resistance against intelligent attacks

Electronic locking cylinder respectively their components shall not be overcome by intelligent attacks within defined resistance times. The resistance times for electronic locking cylinders are for

- Class A, AZ 10 min
- Class B, BZ 30 min
- Class B+, BZ+ 90 min
- Class C, CZ, C+, CZ+ 90 min

The resistance against intelligent attacks is to be proven also for a non-expert installation (e.g. without mounting of a steel door plate).

5.10 Requirements on entering and processing of codes

5.10.1 Preface

The codes entered via the input device are converted electronically and transmitted to the processing unit.

Note: Requirements on using biometrics (here: entering and processing of biometric codes) are in preparation. For the time being it is to proceed according to the following requirements.

Processing units may provide the possibility that they only accept the (in principle correct) code at certain times as authorisation (programming of time slots). Further limitations may be programmed.

5.10.2 Input device

Input devices shall be designed in a way that in blocked state an access to security relevant components is not possible from the attack side without obvious durable traces or damages visible to the user.

5.10.3 Input time

The time between two inputs (or part inputs of a code) shall not exceed 30 s. If this time has lapsed all inputs shall be deleted.

5.10.4 Code carrier for physical codes

Code carrier for physical codes (e.g. smart cards) shall be designed such that it is not possible to copy them by simple means.

Unchangeable physical codes shall be chosen by random.

The code carrier shall not bear uncoded information regarding the code.

5.10.5 Contactless transfer of codes

If for entering the code no direct contact of the code carrier and the input device is necessary (e.g. when using a transponder) the transfer of the opening code shall be performed encrypted.

The transfer of the code shall be possible only after a deliberate action of the user. Reading of the transponder and identifying of usable information by a third party shall not be possible.

5.10.6 Overlay codes

The use of not documented overlay codes e.g. for releasing the lock after a maloperation or a malfunctioning of the lock is not admitted. Functions which release the lock at malfunctions without a previous code input neither are permitted.

5.10.7 Code changing

It shall be possible to delete, block or change opening codes with which electronic locking cylinders are operated. The code changing shall be possible only after entering of the authorisation code or the respective opening code.

5.10.8 Code characteristics

Opening codes as well as authorization codes shall fulfill at least the requirements according to table 5.05.

Class of the locking cylinder	Minimum number of possible combinations	Minimum number of used figures or letters at mnemonic codes (length of code)
A	10,000	4
B	100,000	5
C	1,000,000	6

Table 5.05: Requirements for codes

When using only one opening code the minimum number of possible combinations according to table 5.05 is to be considered. When using several opening codes (parallel codes) the minimum number of possible combinations according to table 5.05 shall be multiplied with the number of parallel codes.

Example: For 5 parallel codes 50,000, 500,000 resp. 5,000,000 combinations for electronic locking cylinders of class A, B and C shall be available.

5.10.9 Event recorder

For locking cylinders which can be operated with parallel codes at least the number of openings as indicated in table 5.06 shall be filed. At least indications on which sequence the electronic locking cylinder has been operated with which codes, shall be filed.

In case of failure of the power supply the filed data shall be kept at least for one year.

It is up to the manufacturer if – although this is not required – a timely correlation (date, day time) of operations shall be effected.

Class of the locking cylinder	Minimum number of openings to be stored	Minimum number of lockings to be stored	Time and date of operation processes are to be stored
A	not required	not required	not required
B	30	not required	not required
C	100	50	Yes

Table 5.06: Event recorder

5.10.10 Faulty inputs

The possibility to enter faulty codes shall be limited to the number as indicated in table 5.07 for one hour. If this maximum number of faulty codes is exceeded in one hour a further input respectively the processing of further inputs shall not be possible until the hour has expired.

Example: If for a locking system of class C 10 faulty inputs had been made within 10 min, a further input shall not be possible for 50 min.

Class of the locking system	Maximum number of faulty inputs per hour
A	30
B	20
C	10

Table 5.07: Faulty inputs

However, the time limitation and the limitation of faulty code inputs per hour may be omitted if on base of

- a high number of possible combinations per code
- the time necessary for the system for evaluation of a combination

at least the same time has to be used for the input of all combinations which would also be necessary for a procedure according to table 5.07 for the fulfillment of the requirements according to clause 5.10.7.

Example: For a product providing a 27-bit code and using 3 s for the processing of a code, the input of all combinations would last around 12.8 years.

The same time would have to be used for an input of all combinations of a 32-bit code if for the processing of a code for this system 0.09 s would be necessary.

In both cases the requirements for class A are fulfilled.

Note: The required number of possible combinations may be realized by the use of biometric code carrier in connection with a suitable processing.

5.10.11 Cut-off Times

Active cut-off times, e.g. after a repeated input of faulty codes shall be indicated to the user.

5.10.12 Protection of codes

Audible or visible signals shall give hints nor on the entered code neither on sequences of the code.

Key pads for the entering of codes for locking cylinders of class C shall be protected against access by spotting the entering process. Beyond an angle of $\pm 70^\circ$, measured at the vertical, spying out of the code input shall not be possible.

For key pads of locking cylinders of class C precautions shall be taken, which inhibit the identification of a code put in (e.g. on base of finger prints).

5.10.13 Power supply

For electronic locking cylinders which are powered by batteries the battery capacity shall be monitored. If batteries are almost discharged this shall lead to an audible or visible warning signal during or directly after the operation procedure. After the first warning signal at least 50 complete locking operations shall be possible.

For locking cylinders, powered by a mains supply, at least 50 complete locking operations shall be possible, too, after failure of the mains supply.

The previously mentioned requirement may be omitted if no locking operation is necessary for the change of discharged batteries respectively an opening of the locking cylinder is necessary or if the operation unit disposes of possibilities for coupling an energy source.

5.11 Resistance against physical attacks

5.11.1 Resistance against attacks with metal cutting tools

Deviating from DIN EN 1303, clause 4.7.5 locking cylinders tested according to clause 6.6.1 of these guidelines shall resist a minimum time as shown in table 5.08 in case of attacks with metal cutting tools.

Class	Minimum resistance time
A	3 min
B	6 min
C	10 min

Table 5.08: Resistance against attacks with metal cutting tools

5.11.2 Resistance against attacks with pulling tools

Deviating from DIN EN 1303, clause 4.7.8 locking cylinders tested according to clause 6.6.2 of these guidelines shall resist a minimum time as shown in table 5.09 in case of attacks with pulling tools.

Class	Maximum pulling force	Minimum resistance time
A	15 kN	3 min
B	15 kN	6 min
C	20 kN	10 min

Table 5.09: Resistance against attacks with pulling tools

In case the technical documentation of the manufacturer describes that the locking cylinder shall be used exclusively with a VdS-approved burglar resistant door plate with pulling protection, the requirements of table 5.09 are considered being fulfilled.

6 Tests

6.1 Preconditions

6.1.1 Test specimen

The manufacturer shall deliver – depending on design – 7 (without pulling protection) up to 10 (with pulling protection) specimen out of the series manufacturing for the laboratory test with the associated code carrier respectively code information to VdS Schadenverhütung.

Furthermore all relevant construction documentation shall be handed in.

If the product is not yet produced in series the test may be performed at prototypes. In this case a re-test at products taken from the series production is necessary for a final evaluation.

6.1.2 Tolerances

If not indicated otherwise, the tolerance for indications of force and torque is $\pm 5\%$.

6.1.3 Test matrix

The individual tests are carried out according to the sequence as in the following test matrix (table 6.01). If one sample fails or becomes damaged during the test it shall be decided on individual basis, after consultation with the manufacturer where appropriate, whether and with which step the test program will be continued.

Test No	Test	VdS 2156 clause	Test specimen									
			1	2	3	4	5	6	7	8	9	10
Initial test												
1	Completeness	6.2.1	x	x	x	x	x	x	x	x	x	x
2	Identity	6.2.2	x	x	x	x	x	x	x	x	x	x
3	Manufacturers declaration	6.3.1	x									
General tests												
4	Mounting instructions	6.3.2	x									
5	Operation manual	6.3.3	x									
6	Marking	6.3.4	x									
7	Failure of power supply	6.3.5	x	x	x							
8	Durability	6.3.6	x	x	x							
Protection against environmental influences												
9	Environmental classes	6.3.7.1				x						
10	Climates	6.3.7.2				x						
11	Protection against corrosion (SO ₂)	6.3.7.3				x						
12	Mechanical influences	6.3.7.4					x					
13	Electromagnetic compatibility	6.3.7.5						x				
Protection against intelligent attacks												
14	Resistance against intelligent attacks	6.4	x	x				x				
Test of input and processing unit												
15	Input device	6.5.1						x				
16	Input time	6.5.2						x				
17	Code carrier for physical codes	6.5.3						x				
18	Contact free transfer of codes	6.5.4						x				
19	Overlay codes	6.5.5						x				
20	Code changing	6.5.6						x				
21	Code characteristics	6.5.7						x				
22	Event recorder	6.5.8						x				
23	Faulty inputs	6.5.9						x				
24	Cut-off times	6.5.10						x				
25	Protection of codes	6.5.11						x				
26	Power supply	6.5.12						x				
Resistance against physical attacks												
27	Physical attack (metal cutting)	6.6.1				x	x	x				
28	Physical attack (pulling force)	6.6.2							x	x	x	
29	Other tests	6.7										x

Table 6.01: Test matrix

6.2 Initial tests

6.2.1 Completeness

It is tested whether the test samples including the corresponding keys/code carrier as well as the required documents and accessories are available completely.

6.2.2 Identity

It is tested by means of visual check and measurements whether the test samples correspond to the information of the manufacturer. Only if no deviations are found at this the subsequent examinations are going to start.

6.3 General tests

6.3.1 Declaration of the manufacturer

It is tested by visual check whether the declaration of the manufacturer was filled in completely according to clause 5.1 and the indications in the technical documentation correspond with the test samples.

6.3.2 Mounting instructions

It is tested by visual check whether a mounting instruction is attached to each locking cylinder according to clause 5.2.

6.3.3 Operation instruction

It is tested by a visual check whether an operation instruction is attached to each locking cylinder according to the requirements of clause 5.3.

6.3.4 Marking

It is tested by a visual check whether the locking cylinder is marked with the required information according to clause 5.4.

Furthermore it is tested, whether all markings are sufficiently steady, e.g. by peeling attempts, wiping with a cloth soaked with water or alcohol or by simple scraping.

6.3.5 Failure of the power supply

By practical tests it is checked whether the electronic locking cylinders securely leave in locked position according to the requirements of clause 5.6 if the power supply fails. Electronic locking cylinders shall not independently unlock after an interruption of the power supply nor shall they be able to be unlocked without the input of a right code.

6.3.6 Durability

The test is described in DIN EN 1303, clause 5.2.1. For locking cylinders with a cam the cam shall be subjected to a force during the turn of the key in an angle of 315° to 45° with a vertical force of 15 N (for example a weight of 1.5 kg; see picture 6.01).

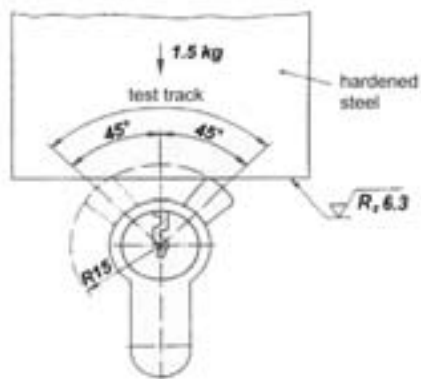

Figure 6.01: Subjected angle range

6.3.7 Protection against environmental influences

6.3.7.1 Indication of environmental class

It is tested by a visual check whether the mounting instruction indicates the environmental class according to the requirements of clause 5.8.1 for all components of the locking cylinder.

6.3.7.2 Climates

The test samples are exposed to dry and/or damp heat according to the requirements of clause 5.8.2. The exact test methods are described in VdS 2110.

Neither during the exposure nor at a function test after the exposure the test sample shall give reasons for objections.

6.3.7.3 Protection against corrosion (SO₂)

The test samples are exposed to SO₂ according to the requirements of clause 5.8.3. The exact test methods are described in VdS 2110.

A function test which is performed after each cycle during the exposure shall not lead to objections.

6.3.7.4 Mechanical influences

The test samples are exposed to mechanical influences according to the requirements of clause 5.8.4. The exact test methods are described in VdS 2110.

Neither during the exposure nor at a function test after the exposure the test sample shall give reasons for objections.

6.3.7.5 Electromagnetic compatibility

The test samples are objected to electromagnetic interferences according to the requirements of clause 5.8.5. The test methods are described in VdS 2110 in detail.

Neither during the exposure nor at a function test after the exposure the test sample shall give reasons for objections.

6.4 Resistance against intelligent attacks

It is checked by practical tests whether the test sample is protected sufficiently against intelligent attacks according to the requirements of clause 5.9.

Attacks without or with only a small number of tools shall not lead to an overcoming of the test sample within the indicated resistance times even with higher technical knowledge.

Note: The test person will determine before beginning of the test which tools are admitted for the test considering the class of the electronic locking cylinder and its construction.

6.5 Test of input device and processing unit

6.5.1 Input device

It is checked by practical tests whether the requirements described in clause 5.10.1 are fulfilled.

6.5.2 Input time

It is checked by practical tests whether the requirements described in clause 5.10.2 are fulfilled.

6.5.3 Code carrier for physical codes

It is tested by a visual check of the test sample whether the manufacturers documentation fulfills the requirements as described in clause 5.10.3.

6.5.4 Contact free transfer of codes

It is tested by a visual check of the manufacturers documentation if the requirements as described in clause 5.10.4 are fulfilled.

6.5.5 Overlay codes

It is tested by a visual check of the manufacturers documentation if the requirements as described in clause 5.10.5 are fulfilled.

6.5.6 Code changing

It is tested by a visual check of the manufacturers documentation if the requirements as described in clause 5.10.6 are fulfilled.

6.5.7 Code characteristics

It is tested by a visual check of the manufacturers documentation if the requirements as described in clause 5.10.7 are fulfilled.

6.5.8 Event recorder

It is tested by a visual check of the manufacturers documentation if the requirements as described in clause 5.10.8 are fulfilled.

6.5.9 Faulty inputs

It is checked by practical tests whether the requirements as described in clause 5.10.9 are fulfilled.

6.5.10 Cut-off times

It is checked by practical tests whether the requirements as described in clause 5.10.10 are fulfilled.

6.5.11 Protection of codes

It is checked by practical tests whether the requirements as described in clause 5.10.11 are fulfilled.

For guaranteeing the security against spying out constructions as e.g. shown in figure 6.02 may be used.

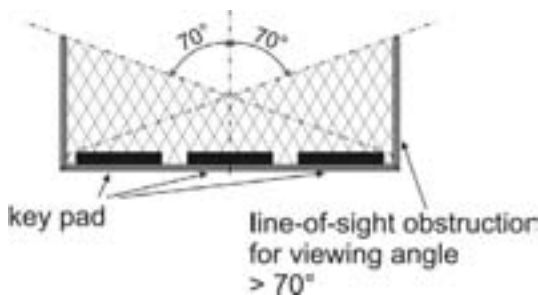

Figure 6.02: Screening of a key pad

6.5.12 Power supply

It is tested by a visual check of the manufacturers documentation if the requirements as described in clause 5.10.12 are fulfilled.

6.6 Resistance against physical attacks

6.6.1 Attacks with metal cutting tools

For the test on resistance against physical attacks the locking cylinders are mounted in a copy of a door made of steel with a mortise lock and a burglar resistant door plate.

The attack is performed with an electric drilling machine with a nominal capacity of 1000 W at maximum and a varying rotation speed of 3000 rpm at maximum. For the drilling process carbide tipped drills or HSS-drills of 2 mm up to 7 mm diameter are used, which may be especially grinded for this purpose.

The drilling machine may dispose of a gauge.

The attack points are determined by the test person on base of the construction drawing and documented in the test protocol.

The locking cylinder is deemed to be overcome if within the resistance time determined for the class (see clause 5.11.1) the locking function has been removed or weakened such that a functional locking process may be performed.

The test time is summed up by the net working times. Change of drills are evaluated with 10 s each as net working times.

The test is performed at three locking cylinders, whereas the worst result is taken for the evaluation.

6.6.2 Resistance against attacks with pulling tools

For the test against resistance with pulling tools the locking cylinders are mounted in a copy of a door made of steel.

It is tried to fasten different screws (either directly or by using electrical tools) into the components to be pulled – the positioning of the pulling screws is determined for each case by the test person – within the minimum resistance times (see clause 5.11.2) of the class.

The maximum pulling force is identified with a mechanic pulling machine.

The locking cylinder is deemed to be overcome if a component of the system may be removed at a force of 15 kN at maximum, so that a functional locking process may be performed.

The requirements are fulfilled if the fastening of a screw is not successful within the minimum resistance time.

6.7 Additional tests

New constructions or production methods may require additional tests.

Changes

Compared with the last version of these guidelines the following changes were made:

- Change of the classification (analogous VdS 2156)
- Offering the application of innovative techniques (e.g. biometry)
- Deletion of the alternative regarding the environmental classes
- Editorial changes

Annex A – Declaration of the manufacturer (normative)

With this we declare, that for manufacturing of the locking cylinder
model _____

in our factory _____

the following organizational measures were taken:

Overlay codes

There are neither overlay non-documented codes for the a.m. cylinder available, which allow the operation or the change of codes of the cylinder without previous input of the opening or authorization code.

Code carrier

The delivery of copied code carriers or further locking cylinders with the same code requires the presentation of an identification approval.

Mounting instructions and operation manual

A German language mounting instruction is attached to every supply of a.m. locking cylinders.

A German language operation manual is attached to every supply of a.m. locking cylinders.

_____, the _____

Stamp/signature